

PHOENIX Series

DH658-135M-5

Hydraulic Pile Driving Rig

SPECIFICATION

October, 2007



Nagoya, Japan

Tel : 81- (52) - 623 - 3529

Fax: 81- (52) - 623 - 4349

Due to company policy of continuous development and improvement, NIPPON SHARYO reserves the right to change designs and specifications without notice.

CONTENTS

	PAGE
1. FEATURES	2
2. SPECIFICATIONS OF PILE DRIVING RIG	4
3. GENERAL DIMENSIONS OF BASIC MACHINE	6
4. POWER TRAIN DIAGRAM OF BASIC MACHINE	7
5. STRUCTURE AND FUNCTIONS	8
6. WORKING CAPACITY TABLE	11
7. GENERAL DIMENSIONS OF DH658-135M-5, M95D-2, 36m LEADER	12
8. LEADER COMPOSITION (TYPE: M95D-2)	13
9. ROPE REEVING CHART AND ROPE SPECIFICATIONS	14
10. TRANSPORTATION DIMENSIONS AND WEIGHT	15
11. STANDARD EQUIPMENTS	17
12. OPTIONAL EQUIPMENTS	18
13. GENERAL CONDITIONS	19

1. FEATURES

1) High performance in hydraulic pile hammer work

Hydraulic Pile Driving Rig, model DH658-135M-5 (here-in-after called “the machine”), is specially designed for various heavy duty pile driving works equipped with a hydraulic pile hammer and an earth auger drive + flight auger, or etc.

2) Durable and stable pile driving work

A durable cylindrical leader with a pair of back stay mechanism provided to specially designed basic machine for pile foundation work purposes gives a high degree of durability and stability of the machine.

3) Excellent maneuverability

The maximum allowable operating weight of 136,000kgf assures facile maneuverability in the site. R.H. and L.H. independent traveling mechanism with a high traction force enables the machine to make both pivot and spin turns, and to steer the crawlers smoothly and continuously.

4) Smooth swing

The swing mechanism with NIPPON SHARYO original reaction device makes operator easy to control sensitive swing motion and accurate positioning of the superstructure.

5) Comfortable operator’s room with low sound level

Well insulated operator room with five (5) wide wind-shields assures bright and quiet operation circumference with minimum fatigue.

6) Easy winch operation

Hydraulic actuated control levers are easy to operate, and high/low winch speed change and winding-stop/automatic braking-rewinding functions can be done by one control lever with mode indicating lamps.

7) Ultra low winch speed control / Constant winch speed control (Optional extra)

Winch rope line speed can be controlled at the desired speed of 1/13 to 1/1 times of its rating. Every winch rope line speed can be maintained at the desired constant speed by “Constant speed controller” as optional extra.

8) Easy maintenance

Adopting floating ring seals in drive tumblers, take-up tumblers and lower track rollers, and sealed bearings to every sheaves require minimum daily maintenance service. A grease-bath type swing pinion gear prolongs its service interval.

9) Low fuel consumption

The machine is powered by a common rail system direct fuel injection type diesel engine with a pair of variable displacement type plunger pumps of efficient performance, accordingly economical operation can be assured.

10) Folding type outrigger beam

Minimizing of useless play of outrigger beams assures less swaying of back stays and leader and reducing re-assembling time of the machine at site.

11) Durable M95D-2 leader

The maximum permissible torque applied to the leader is up to 245 kN (25 ton-m) and the maximum permissible pulling load at the distance of 800mm from the guide pipe center with the front jacks provided is 637 kN (65 ton).

2. SPECIFICATIONS OF PILE DRIVING RIG

2.1 Model of basic machine DH658-135M-5

2.2 Nominal dimensions

1) Overall width in transportation	3,300 mm
2) Crawler overall width in working	4,600 mm
3) Crawler overall width in transportation	3,300 mm
4) Crawler center to center distance in transportation	2,500 mm
5) Crawler center to center distance in working	3,800 mm
6) Crawler shoe width	800 mm
7) Crawler overall length	5,760 mm
8) Tumblers center to center distance	4,900 mm
9) Ground clearance	348 mm
10) Cab width	3,220 mm
11) Cab height	3,310 mm
12) Gantry height (Working)	7,345 mm
13) Overall height (Transportation)	3,299 mm
14) Distance from swing center to rear end (Transportation)	5,508 mm
15) Rear end radius (Counterweight end; working)	5,040 mm
16) Rear end clearance	1,215 mm
17) Distance from swing center to boom foot pin center	1,200 mm
18) Height from boom foot pin center	2,030 mm

2.3 Operation speed

1) Main, auxiliary and third drums, winding speed (Low)	* 30 m/min.
2) Main, auxiliary and third drums, winding speed (High)	* 61 m/min.
3) Fourth drum, winding speed (Optional extra)	* 39 m/min.
4) Leader drum, winding speed	* 47 m/min.
5) Swing speed	2.4 min ⁻¹
6) Travel speed	*0.9 km/hr.
7) Gradeability (Basic machine)	40 %
8) Weight of basic machine	456 kN (46,500kgf)
9) Counterweight	(5,500 + 2,700 x 2pcs. + 3,600 + 4,000 kgf) 181 kN (18,500kgf)
10) Standard leader length	21 m
11) Maximum permissible operating weight	1,334 kN (136,000kgf)
12) Ground contacting area	78,400 cm ²
13) Average ground pressure (Maximum operating weight of 1,334 kN) ..	170 kPa (1.73 kgf/cm ²)

2.4 Diesel engine

- 1) Maker Hino Motors, Ltd.
2) Model J08E-TM diesel engine
3) Type Water cooled, 4-cycle, Overhead valve, in-line
6-cylinder, direct fuel injection, turbo-charged.

No. of cylinder x bore x stroke	6 x 112 mm x 130 mm
Total displacement	7,684 cc
Compression ratio	18.0 : 1
Rated output	159 kW / 2000 min ⁻¹ (216PS / 2000 min ⁻¹)
Maximum torque	797 N·m / 1600 min ⁻¹ (81.3 kgf·m / 1600 min ⁻¹)
Fuel consumption rate	208 g/kW · hr (153 g/PS · hr)

2.5 Battery DC24V-120A·h x 2 pcs.

2.6 Fuel tank capacity 250 liters

Note1: This diesel engine complies with EU StageIII A and USA Tier3 of emission standards.

Note2: “*” marked speed changes in accordance with load

3. GENERAL DIMENSIONS OF BASIC MACHINE

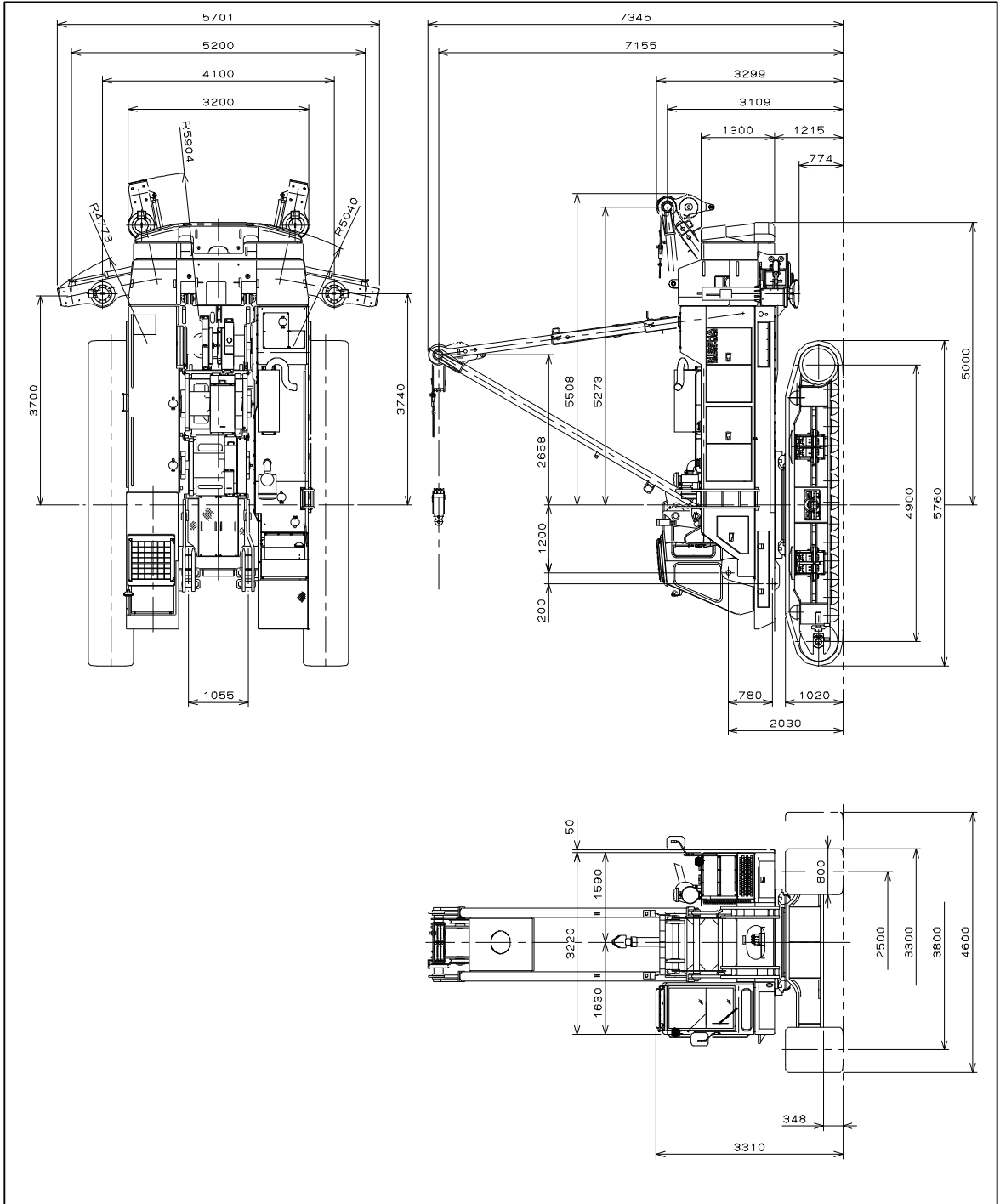

4. POWER TRAIN DIAGRAM OF BASIC MACHINE

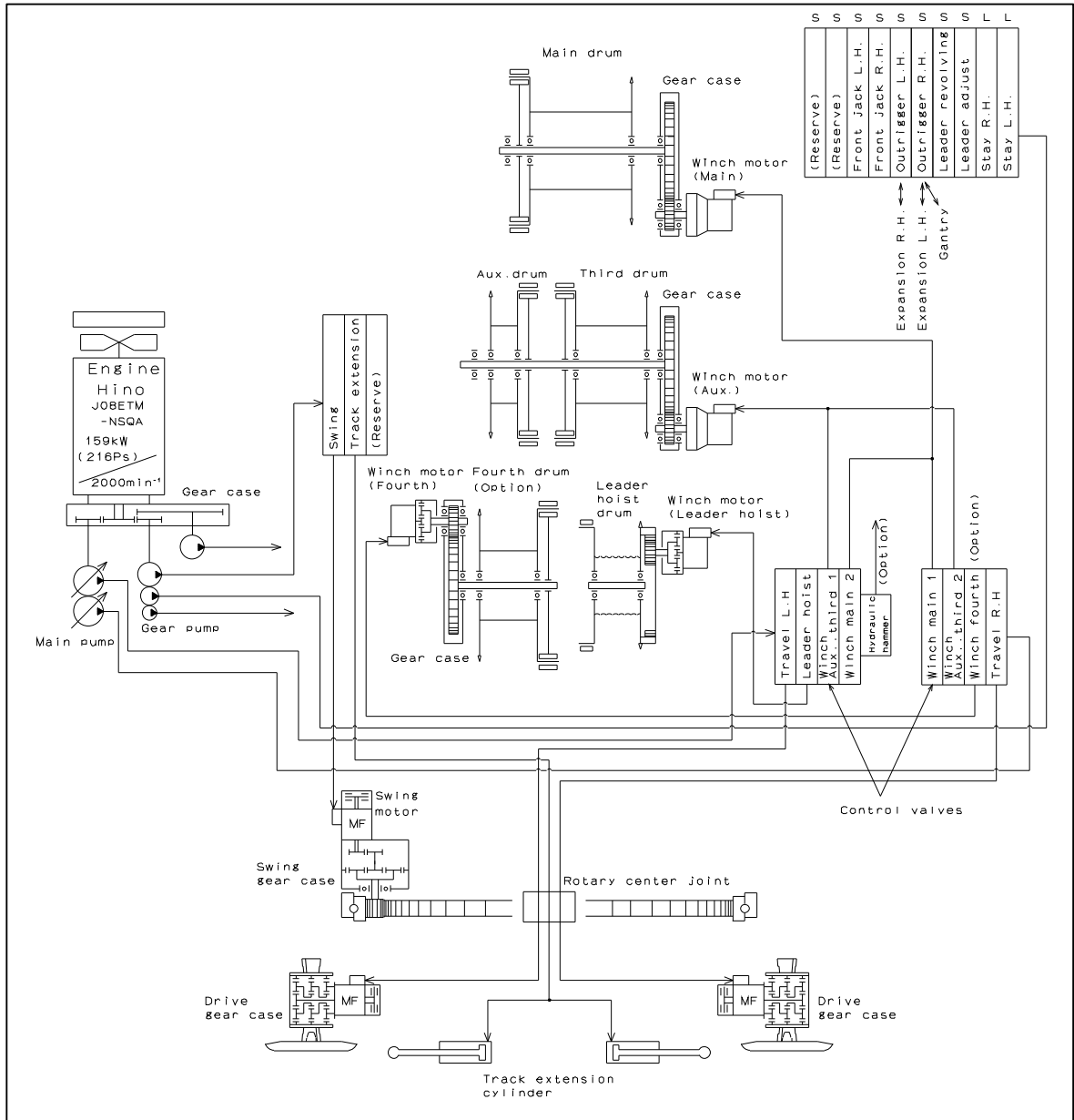

5. STRUCTURE AND FUNCTIONS

5.1 Upper revolving superstructure

All welded, stress relieved and precision machined unit, specially designed for rigidity and durability.

5.2 Winch drums

1) Main, auxiliary, third, fourth (optional extra) and leader winch drums are of special alloy cast iron.

2) Grooved leader drum is mounted on a drum shaft and driven independently by a hydraulic motor.

3) Main drum is mounted on ball race bearings on single drum shaft and driven independently by one hydraulic motor.

Auxiliary and third drum are mounted opposite each other on ball race bearings on single drum shaft and driven by one hydraulic motor.

4) Fourth drum (optional extra) is mounted on ball race bearings on single drum shaft and driven independently by one hydraulic motor.

5) Drum clutch system

Main, auxiliary, third and fourth drums (optional extra) are equipped with internal expanding friction clutch bands powered by respective hydraulic clutch cylinders and ensure both of power controlled lowering and free-fall lowering actions.

6) Drum brake system

Main, auxiliary, third and fourth (optional extra) drums are equipped with external contracting friction bands powered by treading respective brake pedals.

7) Leader hoisting/lowering mechanism

Completely independent operation from other winch functions.

Both of hydraulic brake and spring-loaded/hydraulic released band brake offer positive and safe stopping of leader action.

8) Drum pawl lock

Main, auxiliary, third, fourth (optional extra) and leader drums are equipped with electrically operated pawl locks for safe operation.

5.3 Swing mechanism

1) Swing motor

Axial piston motor with built-in planetary reduction gear.

2) Swing bearing

Sealed ball race bearing with a heat-treated internal gear.

3) Swing brake

Spring loaded and hydraulic released negative brake is installed.

4) Swing lock

Manually operated mechanical lock with a rod tip which is engaged in the hole of track frame during transportation and assembling, whenever needed.

5.4 Operator room

Roomy, completely independent operator's room has safety glass windshields giving super blighting and excellent all-round visibility.

- 1) Control levers and instruments are arranged in convenient trouping, reducing unnecessary moves for operator.
- 2) Comfortable reclining seat is adjustable.

5.5 Undercarriage

- 1) Track frame

All welded, stress relieved, precision machined unit, especially designed for rigidity and durability.

- 2) Crawler side frame

Side frame of all-welded construction can be expanded for better stability of the machine during working and retracted for transportation by hydraulic cylinders equipped as standard.

- 3) Track shoes

Shoes are casting, heat-treated steel, flat and tapered surfaces and are connected by heat-treated steel pins.

- 4) Rollers

Life-lubricated lower rollers, upper rollers and drive tumblers are provided.

13 lower rollers and 2 upper rollers in each side frame, with double rolling surfaces.

5.6 Hydraulic system

A semi-closed circuit hydraulic system with double-plunger pump plus 3-gear pump assures both independent and simultaneous operations of all functions.

5.6.1 Main pump (Double-plunger pump)

Type	Plunger pump 1 Variable displacement Total power control	Plunger pump 2 Variable displacement Total power control
Setting pressure	31.4 MPa (320 kgf/cm ²) (314 bar)	31.4 MPa (320 kgf/cm ²) (314 bar)
Oil flow	214 lit./min.	214 lit./min.
Applications	Travel (L.H.) Leader drum Aux./third drum (low) Main drum (high)	Travel (R.H.) Main drum (low) Aux./third drum (high) Fourth drum (Optional extra)

5.6.2 Gear pump

Type	Gear pump 1	Gear pump 2	Gear pump 3
Setting pressure	20.6 MPa (210 kgf/cm ²) (206 bar)	17.2 MPa (175 kgf/cm ²) (172 bar)	5.4 MPa (55 kgf/cm ²) (54 bar)
Oil flow	130.0 lit./min.	74.4 lit./min.	34.8 lit./min.
Applications	Swing Expansion of crawlers	Front-end attachments	Pilot circuit

5.6.3 Hydraulic motor

- 1) Swing motor 1-fixed volume axial piston motor with brake.
- 2) Winch (Main) 1-fixed volume radial piston motor with counter balance valve
 (Aux./ third) 1-fixed volume radial piston motor with counter balance valve
 (Fourth) 1-fixed volume axial piston motor with counter balance valve
- 3) Winch (Leader) 1-fixed volume axial piston motor with counter balance valve
- 4) Travel 2-fixed volume axial piston motor with spring loaded/
 hydraulic released negative brakes and relief valves.

5.6.4 Hydraulic oil tank capacity : 390 liters

6. WORKING CAPACITY TABLE



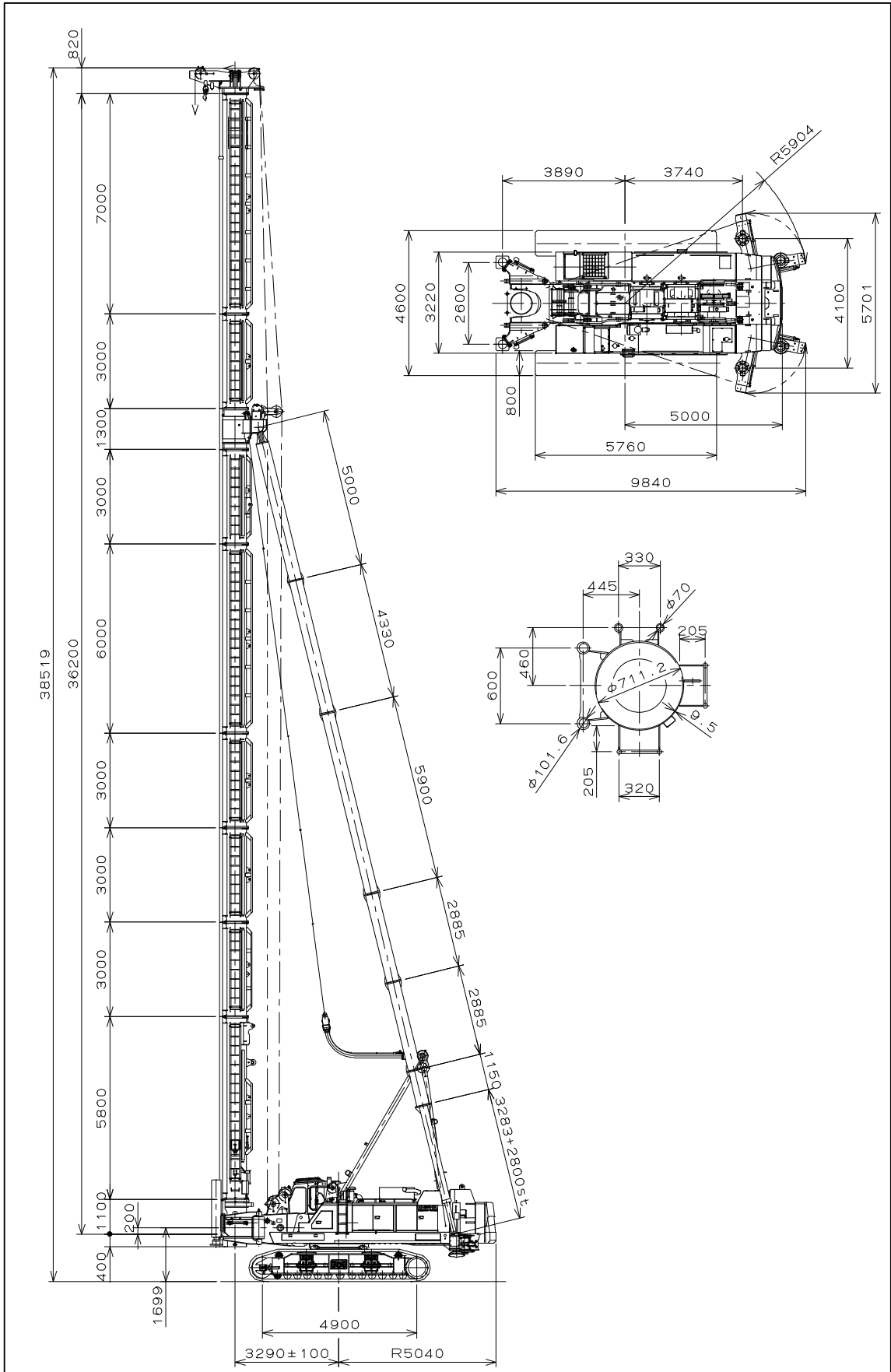

Working capacity table (DH658-135M-5 M95D-2)										159kW(216PS) /2000min ⁻¹								
										0.9 km/h								
										M95D-2								
										3.0M								
										18.5 t								
										46.5 t								
										Average ground pressure (without pile)								
										kPa								
										kgf/cm ²								
Class	Hammer Weight t	Cap Weight t	Auger drive		Screw		Leader		Pile		Vertical stability (with pile) Deg.		Backward inclination		Total operationg weight (without pile) t	Average ground pressure (without pile) kPa		
			Class	Weight t	Length m	Weight t	Length m	Weight t	Length m	Length m	Weight t	For/aft	Side	Angle Deg.			For/aft	Side
NH-150B	33.5	4.5	—	—	—	—	—	21	11	10.0	5.2°	16.4°	20°	10.5°	16.7°	131.0	164	1.67
NH-115B	27.5	3.5	—	—	—	—	—	27	17	10.0	5.4°	12.9°	15°	6.6°	13.2°	127.5	159	1.63
NH-100	22.5	3.5	—	—	—	—	—	33	23	10.0	5.3°	10.7°	—	—	—	125.9	157	1.61
MH80B	19.2	4.0	—	—	—	—	—	33	25	10.0	5.5°	10.6°	—	—	—	122.7	153	1.57
MH72B	18.4	3.0	—	—	—	—	—	36	28	10.0	5.4°	10.0°	—	—	—	122.1	153	1.56
—	—	—	—	—	—	—	—	30	23	10.0	5.5°	12.4°	—	—	—	131.5	164	1.68
—	—	—	—	—	—	—	—	30	23	10.0	7.4°	13.2°	—	—	—	131.8	165	1.68
NH-70	14.3	0.5	—	—	—	—	—	6.6	33	27	10.0	5.1°	9.4°	—	—	130.6	163	1.67
NH-70	14.3	0.5	—	—	—	—	—	12.8	27	21	10.0	5.3°	10.6°	—	—	135.8	170	1.73

Note : 1. The table above shows based on NIPPON SHARYO standard specification on firm & level surface.
 Contact us when special specifications are required.
 2. The maximum leader length of self-erection is 27m with the front jack provided.
 3. Use an assistant crane when erecting longer leader than 27m.
 4. The permissible lifting load of the pile suspension rope $\phi 20$ is 5 tons with single-part line and 10 tons with two-part line. Never allow to exceed the permissible lifting load.
 Consult us when using ropes having other specifications and 3 to 4-part line.
 5. Take the safety factor of 6 and more for the auger suspension rope.
 6. Guide pipe of $\phi 101.6 \times 600$ side is used for equipping NH-150B, NH-115B, NH-100, MH80B, MH72B, NAS120. NAS200, NAD150, NAT240 and $\phi 70 \times 330$ guide pipe for NH-70.
 7. Use outrigger jacks when any backward batter pile driving is carried out. The maximum allowable backward better angle is up to 20 degrees. Consult us if any different condition than the above is required.
 8. The maximum permissible operation weight is up to 136 tons.
 9. The maximum permissible torque of the earth auger is up to 245 kN (25 tf·m).
 10. The maximum permissible extraction load on the top of leader is 637 kN (65 tons) with the leader length 27m and the distance between the auger center and guide pipe center to be 800mm. Provide the front jacks when the auger extraction force exceed 510 kN (52 tons).
 Pay special attention when travelling then machine with the condition marked by *.
 The weight marked by ☆ includes the weight of its casing tube.

7. GENERAL DIMENSIONS OF DH658-135M-5, M95D-2, 36M LEADER

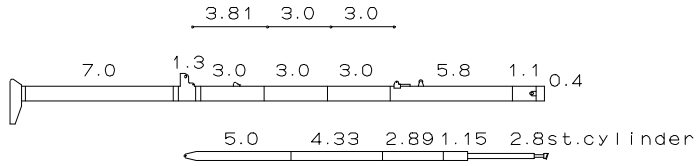

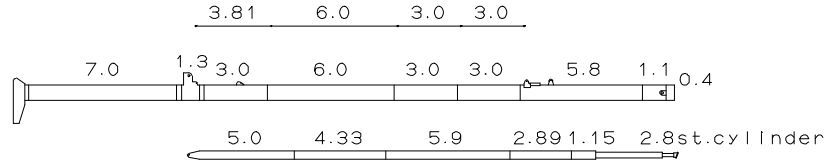
8. LEADER COMPOSITION (TYPE : M95D-2)

Leader length (m)	Composition
<p>21 (Standard)</p>	<p>Pendant rope $\phi 37.5$</p>  <p>Leader</p> <p>Stay</p>
24	
27	
30	
33	
36	

9. ROPE REEVING CHART AND ROPE SPECIFICATIONS

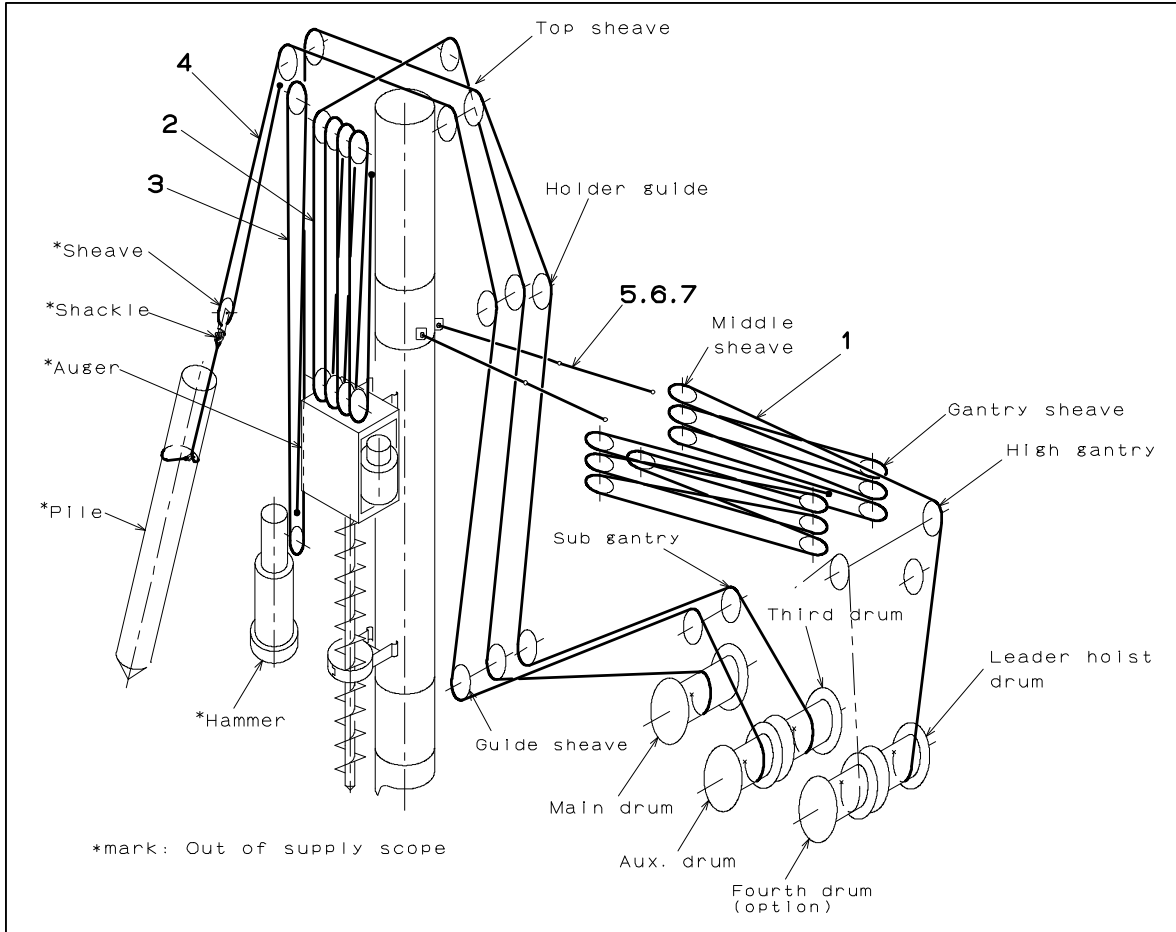

No.	Rope name	Rope specifications	Rope dia. (Braking force)	Rope length
1	Leader	IWRC 6 x Fi(29) Ordinary Z-twist	φ 16 188kN(19.2t)	210m
2	Auger	IWRC 6 x Fi(29) Ordinary Z-twist	φ 20 294kN(30.0t)	300m
3	Hammer	IWRC 6 x Fi(29) Ordinary Z-twist	φ 20 294kN(30.0t)	150m
4	Pile	IWRC 6 x Fi(29) Ordinary Z-twist	φ 20 294kN(30.0t)	120m
5,6	Pendant	7 x 7 + 6 x Fi(29) ordinary Z-twist	φ 37.5 1030kN(105t)	3,6m
7	Pendant	IWRC 6 x Fi(29) Ordinary Z-twist	φ 37.5 1030kN(105t)	3.81m

10. TRANSPORTATION DIMENSIONS AND WEIGHT

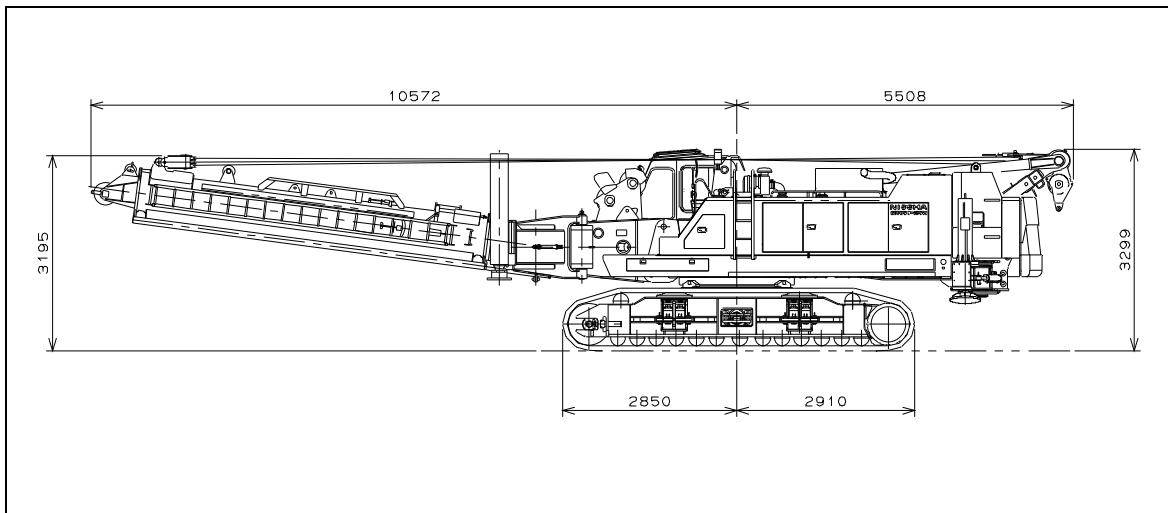

1) Superstructure 28.4 t (29.5 t with fourth drum option)

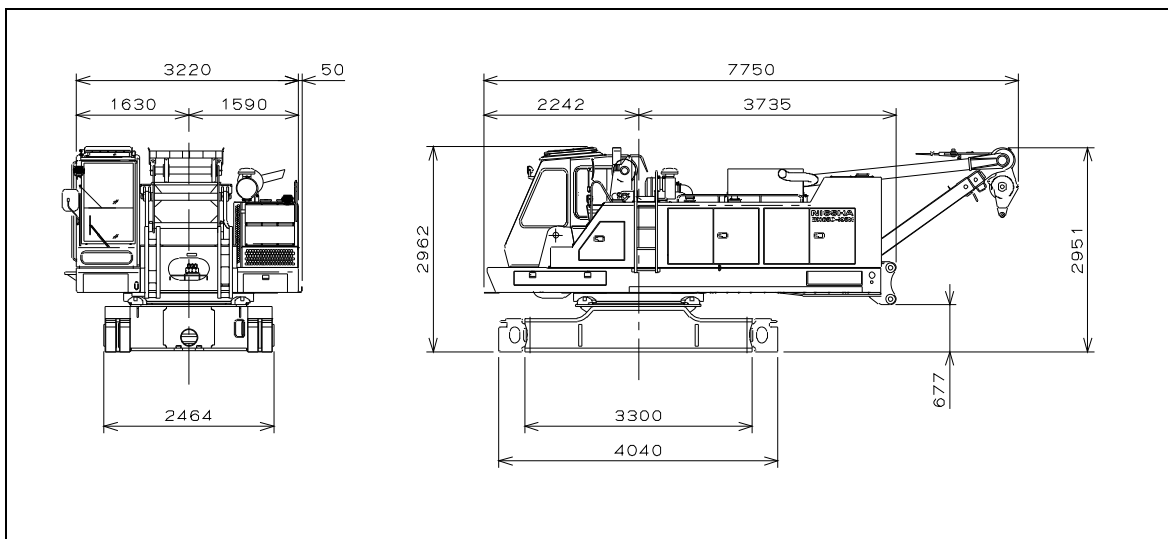

2) Crawler side frame 7.0 t x 2 pc

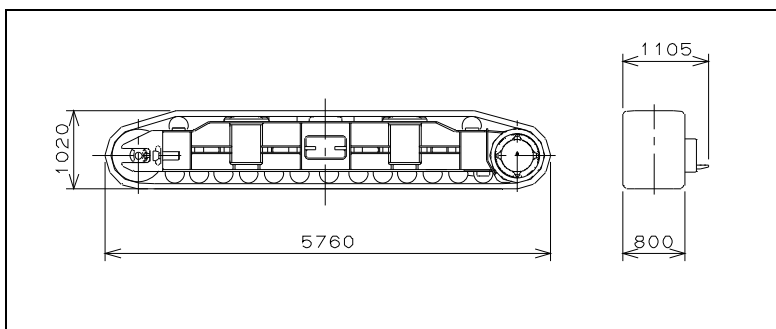

3) Outrigger 4.0 t

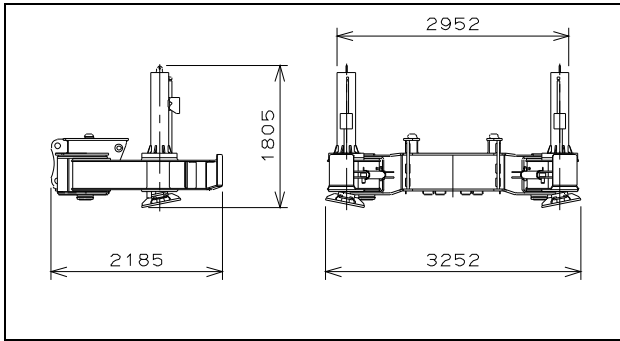

4) Counterweight

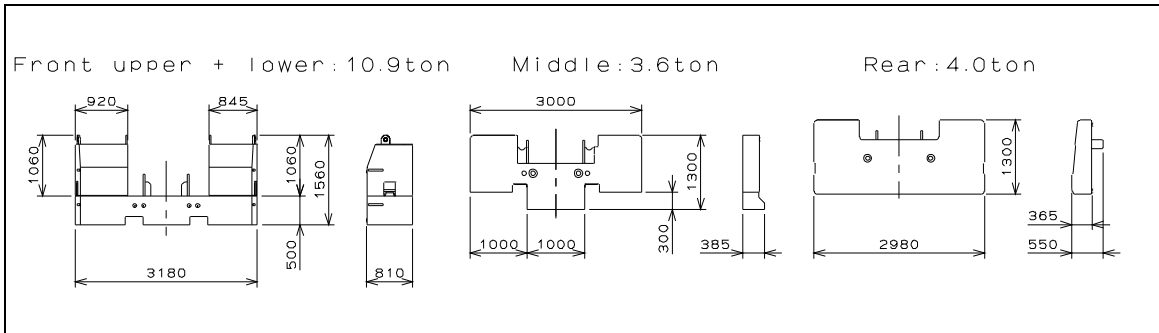

5) 5.8 m leader lower 2.6 t

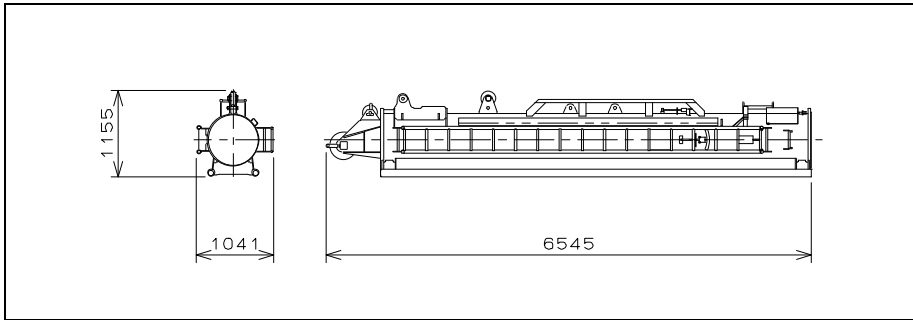

6) Leader bracket (with front jacks and revolver) 10.5 t

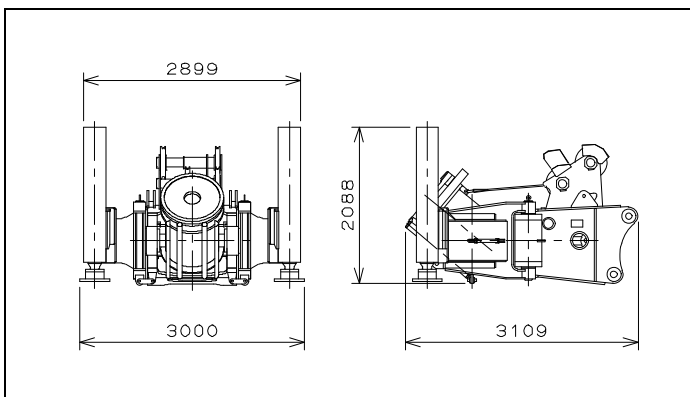

11. STANDARD EQUIPMENTS

1) Basic machine

- 18.5 ton counter weight
- Four drums of main, auxiliary, third and leader
- Low speed winch control valve
- Check Monitor (Engine condition etc..)
- 10 range control valve (2 lines are provided P.T.O.)
- Head lamps (80Wx2)
- Room lamp (20Wx1)
- Windshield wiper (Roof, Front upper, Lower)
- Air conditioner in operator's cab
- A pair of outrigger jacks
- Electric fan in operator's cab
- Radio (AM/FM auto-tuning)
- Electric fuel pump
- Ash tray
- Cigar lighter (DC24V)
- Sight level gauge with a bubble
- Rear-view mirror (R.H. & L.H.)
- Floor mat
- Stone guard for roof window
- Ladder for cab (R.H. & L.H.)
- Step (Crawler side frame)
- Tool box
- Standard tool set

2) Pile driving front-end attachments

- 21 m leader, Revolving type, Model: M95D-2
- Double guide pipe (ϕ 70 x pitch 330 and ϕ 101.6 x pitch 600mm)

Composed of

- | | |
|----------------------------|-------|
| 0.40 m lower leader | 1 pc. |
| 1.1 m revolver | 1 pc. |
| 5.8 m lower leader | 1 pc. |
| 3 m lower leader | 1 pc. |
| 3 m upper leader | 1 pc. |
| 1.3 m holder | 1 pc. |
| 7 m upper leader | 1 pc. |
| Top sheaves assembly | 1 set |
- Leader bracket
 - A pair of self-erecting jack

3) Safety device

- Swing lock & alarm lamp
- Swing alarm & buzzer, flushing lamps
- Brake pedal unlock alarm
- Neutral braking/free change-over switch
- Neutral braking/free change-over lamp
- Electric pawl lock (Main, auxiliary, third, leader)
- Auger over-hoist preventive device (ϕ 101.6 mm guide pipe side)
- Holder lock for transportation
- Inclinator with alarm (Basic machine & leader)
- Revolver lock (Wedge type)
- Non slip sheet (On the cab)

12. OPTIONAL EQUIPMENTS

- Fourth drum
- Hydraulic P.T.O.
- Ultra low speed winch control valve
- High efficiency heater
- Microphone & Speaker
- Pawl lock indicator
- Deck for Generator or Hydraulic Power Pack (Back side)

e.t.c.

13. GENERAL CONDITIONS

This specification shall cover the standard specification of Hydraulic Pile Driving Rig ; model DH658-135M-5 (here-in-after called “the machine”) manufactured by NIPPON SHARYO, LTD.

The general arrangement and typical dimensions of the machine are shown in the drawings attached.

1) DESIGN AND WORKMANSHIP

The machine shall be designed to perform the maximum efficiency with the least fuel consumption and the lowest maintenance costs.

The workmanship shall be of the first class in all respects.

The machine shall be built for simple mechanical arrangement and easy in inspection and maintenance.

2) MATERIALS

The materials used in the manufacture of the machine shall be of the highest quality, free from defects and imperfections.

Principal materials such as bolts, nuts, seals and steel plates used in the machine confirm to the Japanese Industrial Standards. (Almost equal to ISO9001)

3) TEST AND INSPECTION

Routine test and inspection in our factory shall be final.

4) PAINTING AND LETTERING

Under-coating by anti-rust paint and enamel finishing shall be performed in accordance with manufacturer’s standard practice.

Main parts of the equipment shall be painted in NISSHA Green and other equipment in manufacturer’s standard.

5) SERVICE CONDITIONS

The equipment shall meet the following service conditions.

Ambient temperature: -10 °C or higher and 40 °C or lower.

6) WARRANTY

All the machines specified herein shall be warranted by us for a period of twelve (12) calendar months after the date of being to put into operation, or fourteen (14) months after the date of shipment at a Japanese port, or one thousand engine operation hours according to the service hour meter, whichever is soonest.

The warranty shall cover defects in design, materials and workmanship only, shall not applicable to damage sustained mishandling of the machine or normal wear and tear.

The warranty shall not be applicable to the parts and materials mentioned below.

- ① Linings as brake/clutch bands and disc
- ② Wear plates
- ③ Wire ropes
- ④ Rubber made parts
- ⑤ Seals as o-rings, seal rings, back-up rings, etc.
- ⑥ Gaskets and sheet packings
- ⑦ Filter elements
- ⑧ Batteries
- ⑨ Electric wiring
- ⑩ Glasses
- ⑪ Other quick moving parts
- ⑫ Lubricants

... concluded