

SPEC. F1510B-E-2
Date: April, 1998

SPECIFICATION

“NISSHA”

PHOENIX Series

Hydraulic Pile Driving Rig

Model : DH558-110M-2, M85D

(Standard version)

Quantity: **unit**

October, 1998

NIPPON SHARYO, LTD.

Nagoya, Japan
Tel: 81 - (52) -623-3659
Fax: 81 - (52) -623-4349

CONTENTS

	Page
1. GENERAL CONDITIONS	2
2. FEATURES.....	3
3. SPECIFICATIONS OF PILE DRIVING RIG.....	5
4. GENERAL VIEW OF BASIC MACHINE.....	7
5. POWER TRAIN DIAGRAM	8
6. STRUCTURE AND FUNCTIONS.....	9
7. WORKING CAPACITY TABLE.....	13
8. GENERAL VIEW OF DH558-110M-2, M85D.....	14
9. STANDARD SCOPE OF SUPPLY.....	15
10. OPTIONAL EXTRA DEVICES	15

1. GENERAL CONDITIONS

This specification shall cover the standard specification of NISSHA, Hydraulic Pile Driving Rig; model DH558-110M-2 (here-in-after called "The machine") manufactured by NIPPON SHARYO, LTD.

The general arrangement and principal dimensions of the machine are shown in the drawings attached.

1) DESIGN AND WORKMANSHIP

The machine shall be designed to perform the maximum efficiency with the least fuel consumption and the lowest maintenance costs.

The workmanship shall be of the first class in all respects.

The machine shall be built for simple mechanical arrangement and easy in inspection and maintenance.

2) MATERIALS

The materials used in the manufacture of the machine shall be of the highest quality, free from defects and imperfections.

Principal materials such as bolts, nuts, seals and steel plates used in the machine confirm to the Japanese Industrial Standards. (Almost equal to ISO)

3) TEST AND INSPECTION

Routine test and inspection in our factory shall be final.

4) PAINTING AND LETTERING

Under-coating by anti-rust paint and enamel finishing shall be performed in accordance with manufacturer's standard practice.

Main parts of the equipment shall be painted in NISSHA Green and other equipment in manufacturer's standard.

5) LANGUAGE AND UNIT OF MEASUREMENT

All documentation, such as specifications, manuals, etc. shall be written in English and all of equipment shall be designed in metric system.

6) SERVICE CONDITIONS

The equipment shall meet the following service conditions.

Ambient temperature: -10 or higher and 40 or lower.

7) WARRANTY

All the machines specified herein shall be warranted by us for a period of twelve (12) calendar months after the date of being to put into operation, or fourteen (14) months after the date of shipment at a Japanese port, or one thousand engine operation hours according to the service hour meter, whichever is soonest.

The warranty shall cover defects in design, materials and workmanship only, shall not applicable to damage sustained mishandling of the machine or normal wear and tear.

The warranty shall not be applicable to the parts and materials mentioned below.

- 1) Linings as brake/clutch bands and disc.**
- 2) Wear plates**
- 3) Wire ropes**
- 4) Rubber made parts**
- 5) Seals as o-rings, seal rings, back-up rings, etc.**
- 6) Gaskets and sheet packings**
- 7) Filter elements**
- 8) Batteries**
- 9) Electric wiring**
- 10) Glasses**
- 11) Other quick moving parts**
- 12) Lubricants**

NIPPON SHARYO, LTD.

... concluded

2. FEATURES

1) High performance in hydraulic pile hammer work

The machine is specially designed for various heavy duty pile driving works equipped with a hydraulic pile hammer and an earth auger drive + flight auger, or etc.

2) Durable and stable pile driving work

A durable cylindrical leader with a pair of back stay mechanism provided to specially designed basic machine for pile foundation work purposes gives a high degree of durability and stability of the machine.

3) Excellent maneuverability

The maximum allowable operating weight of 114,000kgf assures facile maneuverability in the site.

R.H. and L.H. independent traveling mechanism with a high traction force enables the machine to make both pivot and spin turns, and to steer the crawlers smoothly and continuously.

4) Smooth swing

The swing mechanism with NIPPON SHARYO original reaction device makes operator easy to control sensitive swing motion and accurate positioning of the superstructure.

5) Comfortable operator's room with low sound level

Well insulated operator room with five (5) wide wind-shields assures bright and quiet operation circumference with minimum fatigue.

6) Easy winch operation

Hydraulic actuated control levers are easy to operate, and high/low winch speed change and winging-stop/automatic braking-rewinding functions can be done by one control lever with mode indicating lamps.

7) Ultra low winch speed control / Constant winch speed control (Optional extra)

Winch rope line speed can be controlled at the desired speed of 1/13 to 1/1 times of its rating.

Every winch rope line speed can be maintained at the desired constant speed by "Constant speed controller" as optional extra.

8) Easy maintenance

Adopting floating ring seals in drive tumblers, take-up tumblers and lower track rollers, and sealed bearings to every sheaves require minimum daily maintenance service. A grease-bath type swing pinion gear prolongs its service interval.

9) Low fuel consumption

The machine is powered by a direct fuel injection type diesel engine with a pair of variable displacement type plunger pumps of efficient performance, accordingly economical operation can be assured.

10) Folding type outrigger beam

Minimizing of useless play of outrigger beams assures less swaying of back stays and leader and reducing re-assembling time of the machine at site.

11) Durable M85D leader

The maximum permissible torque applied to the leader is up to 13 ton-m and the maximum permissible pulling load at the distance of 800mm from the guide pipe center with the front jacks provided is 55 ton.

3. SPECIFICATIONS OF PILE DRIVING RIG

3.1 Model of basic machine NISSHA ; DH558-110M-2

3.2 Nominal dimensions

1) Overall width in transportation.....	3,300mm
2) Crawler overall width in working.....	4,400mm
3) Crawler overall width in transportation.....	3,300mm
4) Crawler center to center distance in transportation.....	2,500mm
5) Crawler center to center distance in working.....	3,600mm
6) Crawler shoe width.....	800mm
7) Crawler overall length.....	5,520mm
8) Tumblers center to center distance.....	4,660mm
9) Ground clearance.....	344mm
10) Cab width.....	3,155mm
11) Cab height.....	3,208mm
12) Gantry height (Working).....	6,684mm
13) Overall height (Transportation).....	3,251mm
14) Distance from swing center to rear end (Transportation).....	5,318mm
15) Rear end radius (Counterweight end)	4,940mm
16) Rear end clearance.....	1,040mm
17) Distance from swing center to boom foot pin center	1,160mm
18) Height from boom foot pin center	1,840mm

3.3 Operation speed

1) Main, auxiliary and third drums, winding speed (Low)	* 33m/min.
2) Main, auxiliary and third drums, winding speed (High).....	* 66m/min.
3) Fourth drum, winding speed (Option).....	* 41m/min.
4) Leader drum, winding speed	* 49m/min.
5) Swing speed	3.0 rpm(3.0min ⁻¹)
6) Travel speed	1.0 km/hr.
7) Gradeability (Basic machine)	40%
8) Weight of basic machine	391kN (39,900kgf)
10) Counterweight.....	162kN (9,000 + 3,500+4,000 kgf= 16,500kgf)
10) Standard leader length	21m
11) Maximum permissible operating weight	1118 kN (114,000 kgf)
12) Ground contacting area	74,560cm ²
13) Average ground pressure (Maximum operating weight of 1118kN) ...	150kPa (1.53kgf/cm ²)

3.4 Diesel engine

- 1) MakerHINO MOTOR LTD.
- 2) ModelH07C-TD diesel engine
- 3)TypeWater cooled, 4-cycle, Overhead valve, in-line
6-cylinder, direct furl injection, turbo-charged.
- No. of cylinder x bore x stroke6 x 110mm x 118mm
- Total displacement6,728 cc
- Compression ratio17.5 : 1
- Rated output 132 kW/2100rpm
(180PS/2100rpm)
- Maximum torque 660kN-m/1600rpm
(67kgf-m/1600rpm)
- Fuel consumption rate 234g/kW · hr
(174 g/ps · hr)

3.5 Battery DC24V-120AH x 2 pc.

3.6 Fuel tank capacity 250 liters

4. GENERAL VIEW OF BASIC MACHINE (DH558-110M-2)

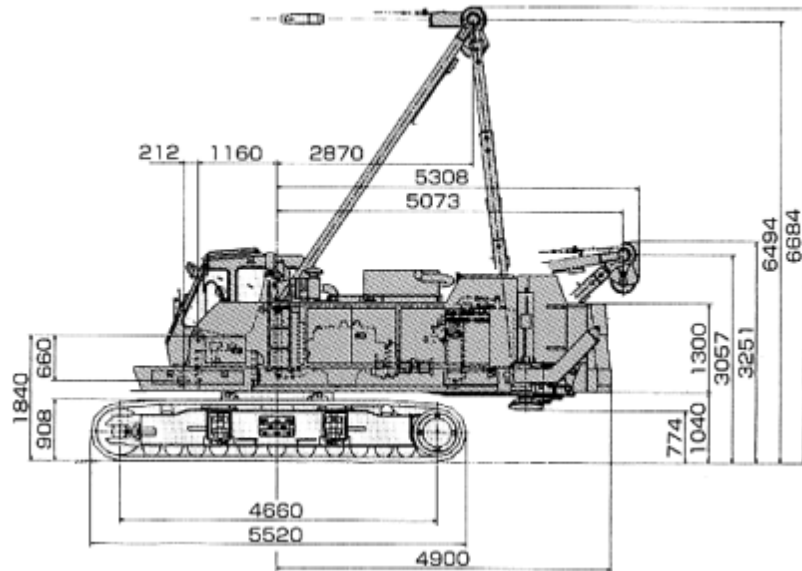
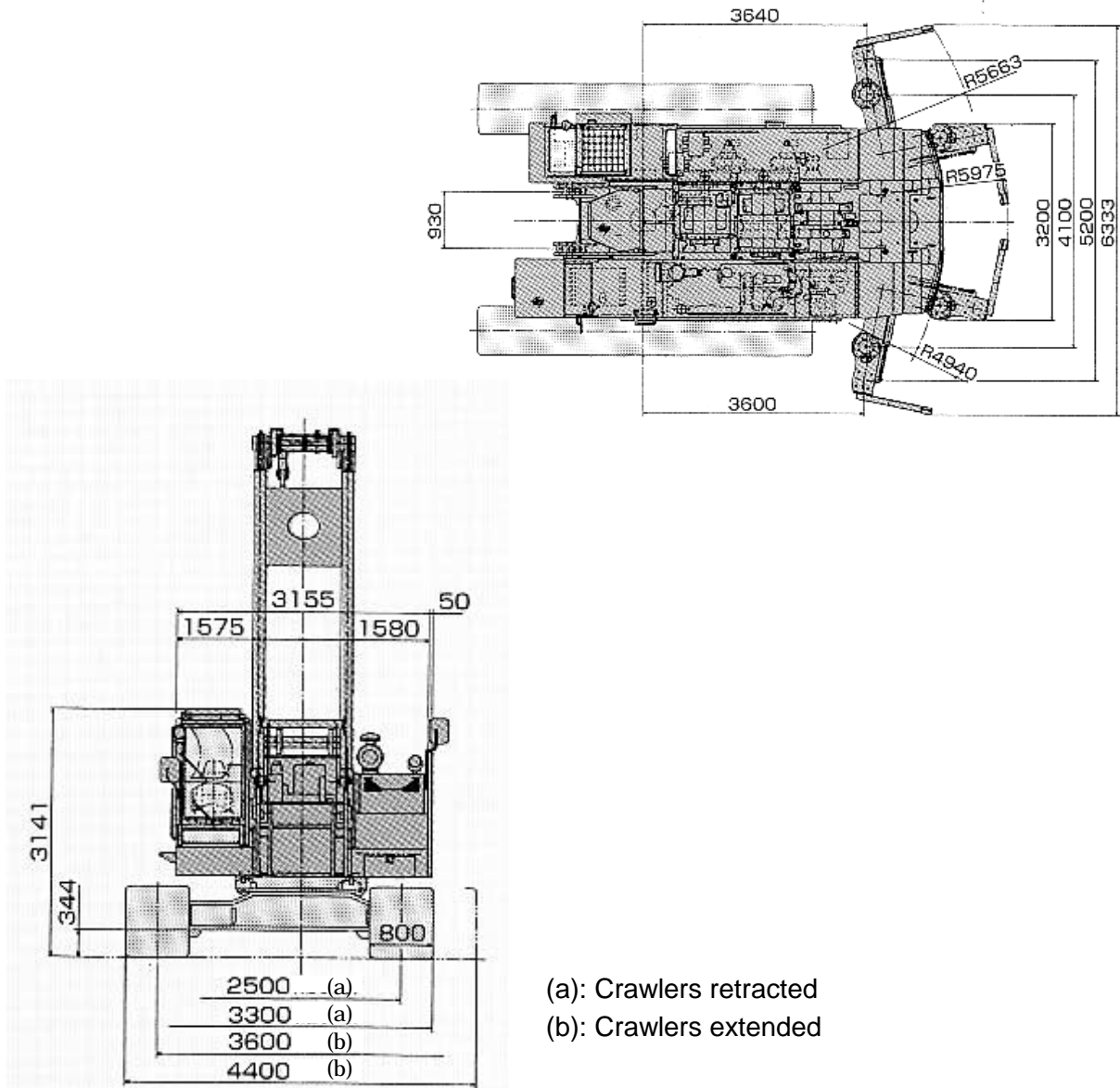

5. POWER TRAIN DIAGRAM (DH558-110M-2 BASIC MACHINE)

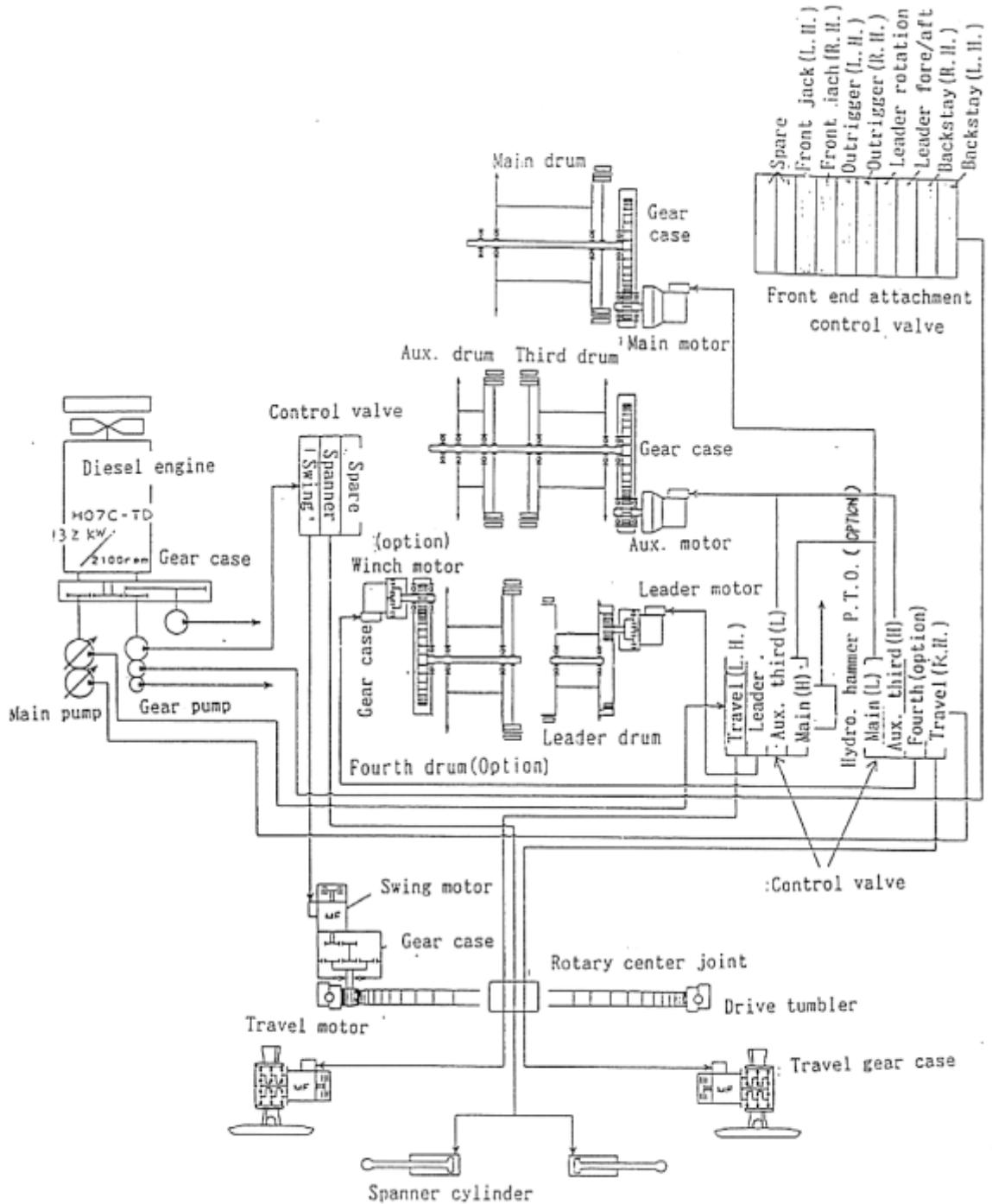

6. STRUCTURE AND FUNCTIONS

6.1 Upper revolving superstructure

All welded, stress relieved and precision machined unit, specially designed for rigidity and durability.

6.2 Winch drums

- 1) Main, auxiliary, third, fourth (Option) and leader winch drums are of special alloy cast iron.**
- 2) Grooved leader drum is mounted on a drum shaft and driven independently by a hydraulic motor.**
- 3) Main drum is mounted on ball race bearings on single drum shaft and driven independently by one hydraulic motor.**
Auxiliary and third drum are mounted opposite each other on ball race bearings on single drum shaft and driven by one hydraulic motor.
- 4) Fourth drum (Optional extra) is mounted on ball race bearings on single drum shaft and driven independently by one hydraulic motor.**
- 5) Drum clutch system**
Main, auxiliary, third and fourth drums are equipped with internal expanding friction clutch bands powered by respective hydraulic clutch cylinders and ensure both of power controlled lowering and free-fall lowering actions.
- 6) Drum brake system**
Main, auxiliary, third and fourth (Option) drums are equipped with external contracting friction bands powered by treading respective brake pedals.
- 7) Leader hoisting/lowering mechanism**
Completely independent operation from other winch functions.
Both of hydraulic brake and spring-loaded/hydraulic released band brake offer positive and safe stopping of leader action.
- 8) Drum pawl lock**
Main, auxiliary, third, fourth (Option) and leader drums are equipped with electrically operated pawl locks for safe operation.

6.3 Swing mechanism

- 1) Swing motor**
Axial piston motor with built-in planetary reduction gear.
- 2) Swing bearing**
Sealed ball race bearing with a heat-treated internal gear.
- 3) Swing brake**
Spring loaded and hydraulic released negative brake is installed.
- 4) Swing lock**
Manually operated mechanical lock with a rod tip which is engaged in the hole of track frame during transportation and assembling, whenever needed.

6.4 Operator room

Roomy, completely independent operator's room has safety glass windshields giving super blighting and excellent all-round visibility.

- 1) Control levers and instruments are arranged in convenient trouping, reducing unnecessary moves for operator.
- 2) Comfortable reclining seat is adjustable.

6.5 Undercarriage

1)Track frame

All welded, stress relieved, precision machined unit, especially designed for rigidity and durability.

2)Side frame

Side frame of all-welded construction can be expanded for better stability of the machine during working and retracted for transportation by hydraulic cylinders equipped as standard.

3)Track shoes

Shoes are casting, heat-treated steel, flat and tapered surfaces and are connected by heat-treated steel pins.

4)Rollers

Life-lubricated lower rollers, upper rollers and drive tumblers are provided.

11 lower rollers and 2 upper rollers in each side frame, with double rolling surfaces.

6.6 Hydraulic system

A semi-closed circuit hydraulic system with double-plunger pump plus 3-gear pump assures both independent and simultaneous operations of all functions.

6.6.1 Main pump (Double-plunger pump)

1) Type	Plunger pump 1 Variable displacement Total power control	Plunger pump 2 Variable displacement Total power control
2) Setting pressure	280 kgf/cm ² (275 bar)	280 kgf/cm ² (275 bar)
3) Oil flow	225 lit./min.	225 lit./min.
4) Applications	Travel (L.H.) Leader drum Aux./third drum(low) Main drum(high)	Travel (R.H.) Main drum (low) Aux./third drum (high) Fourth drum(Option)

6.6.2 Gear pump

1) Type	Gear pump 1	Gear pump 2	Gear pump 3
2) Setting pressure	206 bar (210kgf/cm²)	172 bar (175kgf/cm²)	
3)Oil flow	135 lit./min.	76 lit./min.	
4)Applications	Swing Expansion of crawlers	Front-end attachments	Pilot circuit

6.6.3 Hydraulic motor

- 1) Swing motor.....1-fixed volume axial piston motor with brake.
- 2) Winch(Main).....1-fixed volume radial piston motor with counter balance valve
(Aux./ third)1-fixed volume radial piston motor with counter balance valve
(Fourth)1-fixed volume axial piston motor with counter balance valve
- 3) Winch (Leader) ...1-fixed volume axial piston motor with counter balance valve
- 4) Travel 2-fixed volume axial piston motor with spring loaded/
hydraulic released negative brakes and relief valves.

6.6.4 Hydraulic oil tank capacity : 390 liters

7. WORKING CAPACITY TABLE

Working capacity table (DH558-110M, M85D)

Hammer			Earth auger				Leader	Pile			Vertical drive Stability (with pile) (Degree)		Backward inclination (degree)			Total Operating weight (ton)	Average ground pressure (kg/cm ²)
Class	Weight (ton)	Cap Weight (ton)	Auger drive		Screw			Length (m)	Length (m)	Weight (ton)	For/aft	Side	Angle	Stability			
			Class	Weight (ton)	Length (m)	Weight (ton)								For/aft	Side		
NH-115B	27.5	3.5	-	-	-	-	24	14	10.0	5.4	13.4	17	5.9	13.6	112.3	1.50	
NH-100	22.5	3.5	-	-	-	-	30	20	10.0	5.3	10.7	-	-	-	110.4	1.48	
MH80B	19.5	4.0	-	-	-	-	30	22	10.0	5.4	10.5	-	-	-	107.5	1.44	
MH72B	18.4	3.0	-	-	-	-	33	25	10.0	5.3	9.7	-	-	-	107	1.44	
-	-	-	*NAS200	9.8	28.8	14.4	33	26	10.0	5.7	10.6	-	-	-	112.1	1.50	
-	-	-	*NAT200	11.5	21.1	16.3	27	-	-	8.8	14.0	-	-	-	113.2	1.52	
NH-70	14.3	0.5	NAS120	7.4	26.8	5.9	30	24	10.0	5.3	9.2	-	-	-	114.0	1.53	
NH-70	14.3	0.5	NAS150	9.4	20.8	5.0	24	18	10.0	6.1	10.9	-	-	-	114.0	1.53	

Note:

- The table above shows based on NIPPON SHARYO standard specifications on firm & level surface. Consult us when special specifications are required.
- The maximum leader length of self-erection is 27m with the front jack provided. Use an assistant crane when erecting longer leader than 27m.
- The permissible lifting load of the pile suspension rope of 20 is 5 tons with single-part line and 10 tons with two-part line. Never allow to exceed the permissible lifting load. Consult us when using ropes having other specifications and 3 to 4-part line.
- Take the safety factor of 6 and more for the auger suspension rope.
- Guide pipe of 101.6 x 600.side is used for equipping NH-115B, NH-100, MH80B, MH72B, NAS120, NAS150, NAS200 and NAT200 and 70 x 330 guide pipe for NH-70.
- Use outrigger jacks when any backward batter pile driving is carried out. The maximum allowable backward batter angle is up to 20 degrees. Consult us if any different condition than the above is required.
- The maximum permissible operation weight is up to 114 tons.
- The maximum permissible torque of the earth auger is up to 13 ton-m [127kN].
- The maximum permissible extraction load on the top of the leader is 55tons [539kN] with the leader length of 24m and the distance between the auger center and guide pipe center to be 800mm. Provide the front jacks when the auger extraction force exceeds 44tons [431kN].
- Pay special attention when traveling then machine with the condition marked by *.

8. GENERAL VIEW OF DH558-110M-2, M85D- 33M LEADER

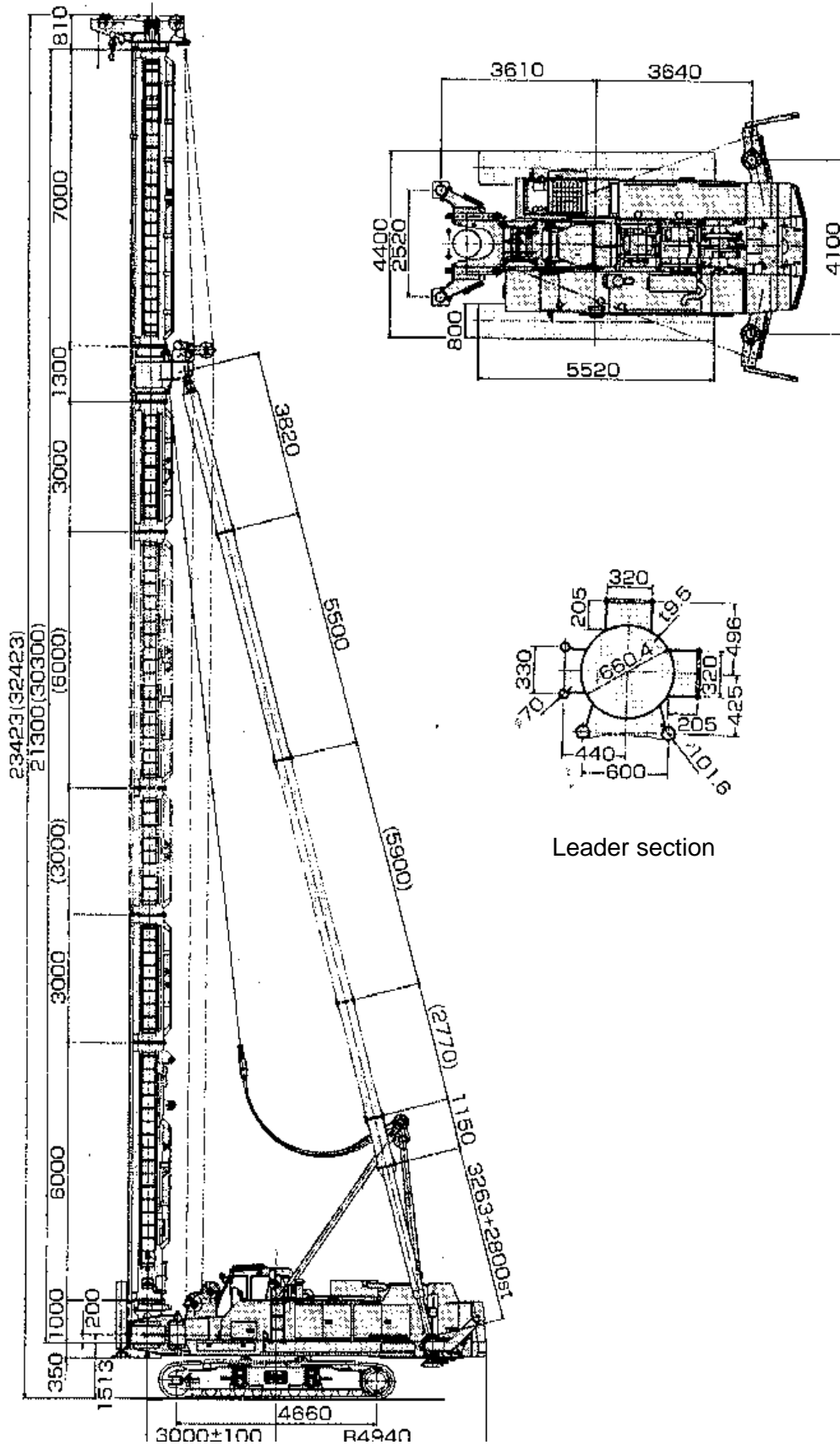

Leader section

9. STANDARD SCOPE OF SUPPLY

1) Basic machine : model DH558-110M-2 1 unit
equipped with

- 16.5 ton counter weight
- Four drums of main, auxiliary, third and leader
- Leader bracket
- A pair of self-erecting jack
- A pair of outrigger jacks
- Electric fan in operator’s cab
- Radio
- Electric fuel pump
- Ash tray and sight level gauge with a bubble

2) Pile driving front-end attachments 1 set

- Leader, Revolving type Model: M85D 21m long
- Double guide pipe (70 x pitch 330 and 101.6 x pitch 600mm)

Composed of

- 0.35m lower leader 1pc.
- 1.0m revolver 1pc.
- 6.0m Lower leader 1pc.
- 3m lower leader 1pc.
- 3m upper leader 1pc.
- 1.3m holder 1pc.
- 7m upper leader..... 1pc.
- Top sheaves assembly.. 1set

3) Standard tool set 1 set

10. OPTIONAL EXTRA DEVICE

- Inclinator 1 set
 (Basic machine and leader)
- Hydraulic P.T.O 1 set
- Fourth drum 1 set
- Ultra-low speed control device 1 set
- Air conditioner in operator’s cab 1 set