

SPEC. F5-2824

Date: October, 1998

SPECIFICATION

“NISSHA”

Crawler Mounted Hydraulic Pile Driving Rig

**Model : DHJ-40, M20DS
(Standard version)**

Quantity: _____ unit

October, 1998

NIPPON SHARYO, LTD.

Nagoya, Japan

Tel: 81 - (52) -623-3659

Fax: 81 - (52) -623-4349

Due to company policy of continuous development and improvement, the right is reserved to change the specifications without notice.

C O N T E N T S

	Page
1. GENERAL CONDITIONS	2
2. FEATURES.....	4
3. SPECIFICATIONS OF PILE DRIVING RIG.....	5
4. POWER TRAIN DIAGRAM (DHJ40).....	7
5. STRUCTURE AND FUNCTIONS.....	8
6. WORKING CAPACITY TABLE.....	11
7. GENERAL VIEW OF DHJ-40, M20DS 15.4M LEADER.....	12
8. LEADER COMPOSITION.....	13
9. STANDARD SCOPE OF SUPPLY.....	14

Due to company policy of continuous development and improvement, the right is reserved to change the specifications without notice.

1. GENERAL CONDITIONS

1) This specifications shall cover the standard specification of NIPPON SHARYO Hydraulic Pile Driving Rig; Model DHJ-40, M20DS (here-in-after called “The machine”) manufactured by NIPPON SHARYO, LTD.

The general arrangement and principal dimensions of the machine are shown in the drawing attached.

2) Design and workmanship

The machine shall be designed to perform the maximum efficiency with the least fuel consumption and the lowest maintenance costs.

The workmanship shall be of the first class in all respects.

The machine shall be built for simple mechanical arrangement and easy in inspection and maintenance.

3) Materials

The materials used in the manufacture of the machine shall be of the highest quality, free from defects and imperfections.

Principal materials such as bolts, nuts, seals and steel plates used in the machine confirm to the Japanese Industrial Standards. (Almost equal to ISO)

4) Test and inspection

Routine test and inspection in our factory shall be final.

5) Painting and lettering

Under-coating by anti-rust paint and enamel finishing shall be performed in accordance with manufacturer’s standard practice.

Main parts of the equipment shall be painted in NISSHA Green and other equipment in manufacturer’s standard.

6) Language and unit of measurement

All documentation, such as specifications, manuals, etc. shall be written in English and all of equipment shall be designed in metric system.

7) Service conditions

The equipment shall meet the following service conditions.

Ambient temperature: -10 deg. C or higher and 40 deg. C or lower.

Due to company policy of continuous development and improvement, the right is reserved to change the specifications without notice.

8) Warranty

All the machine specified herein shall be warranted by us for a period of twelve (12) calendar months after the date of being put into operation, or fourteen (14) months after the date of shipment at a Japanese port, or one thousand engine operation hours according to the service hour meter, whichever is soonest.

The warranty shall cover defects in design, materials and workmanship only, shall not applicable to damage sustained mishandling of the machine or normal wear and tear.

The warranty shall not be applicable to the parts and materials mentioned below.

- 1) Linings as brake/clutch bands and disc.**
- 2) Wear plates**
- 3) Wire ropes**
- 4) Rubber made parts**
- 5) Seals as o-rings, seal rings, back-up rings, etc.**
- 6) Gaskets and sheet packings**
- 7) Filter elements**
- 8) Batteries**
- 9) Electric wiring**
- 10) Glasses**
- 11) Other quick moving parts**
- 12) Lubricants**

NIPPON SHARYO, LTD.

.....Concluded

Due to company policy of continuous development and improvement, the right is reserved to change the specifications without notice.

2. FEATURES

1) High performance in hydraulic pile hammer work

The machine is specially designed as compact as possible for performing light pile driving works in confined job sites equipped with NH-20 hydraulic pile hammer and /or earth auger drive, or sheet pilers.

2) Durable and stable pile driving work

A durable cylindrical leader with a pair of back-stay cylinders give a high degree of durability and stability of the machine.

3) Excellent maneuverability

The maximum allowable operating weight of 43,000kgf (421kN) assures smooth maneuverability in the site.

L.H. and R.H. Independent traveling mechanism enables the machine to make both pivot and spin turns, and to steer the crawlers continuously.

4) Comfortable operator's room

Well insulated operator room with five (5) wide wind-shields assures bright and quiet operation circumference with minimum fatigue.

5) Easy operation

Hydraulic actuated control levers are easy to operate, and high/low winch speeds and winging-stop-rewinding actions can be done by one control lever.

7) Easy maintenance

Adopting floating ring seals in drive tumblers, take-up tumblers and lower track rollers, and sealed bearings to every sheaves requires minimum daily maintenance service. A grease-bath type swing pinion gear prolongs its service interval.

8) Low fuel consumption

The machine is powered by a direct fuel injection type diesel engine with variable displacement type plunger pumps of efficient performance, accordingly economical operation can be assured.

9) The leader can be folded at its lower end for minimizing overall length in transportation and be stored over the base machine for facile assembling work at the job site.

Due to company policy of continuous development and improvement, the right is reserved to change the specifications without notice.

3. SPECIFICATIONS OF PILE DRIVING RIG

- 3.1 Model of basic machine : NIPPON SHARYO DHJ-40**
- 3.2 Nominal dimensions**
- 1) Overall width in transportation : 2,750mm
 - 2) Crawler overall width in working : 3,100mm
 - 3) Crawler overall width in transportation : 2,750mm
 - 4) Crawler center to center distance in transportation : 2,150mm
 - 5) Crawler center to center distance in working : 2,500mm
 - 6) Crawler shoe width : 600mm
 - 7) Crawler overall length : 4,335mm
 - 8) Tumblers center to center distance : 3,475mm
 - 9) Ground clearance : 374mm
 - 10) Cab width : 2,669mm
 - 11) Cab height : 3,040mm
 - 12) Overall height (Transportation) : 3,250mm
 - 13) Distance from swing center to rear end (Transportation) :14,600m
with 15.5m leader
 - 14) Rear end radius (at 4.3ton counterweight end) : 3,280mm
(at 5.7ton counterweight end) : 3,330mm
 - 15) Rear end clearance : 958mm
- 3.3 Operation speed**
- 1) Main, auxiliary, drum, winding speed * 58m/min.
 - 2) Main, auxiliary drum, unwinding speed * 58m/min.
 - 3) Third drum, winding speed * 58m/min.
 - 4) Third drum, unwinding speed * 58m/min.
 - 5) Swing speed 2.0 rpm
 - 6) Travel speed 1.9km/hr.
- 3.4 Gradeability (Basic machine) 40%**
- 3.5 Counterweight4,300kgf (39kN)**
Optional extra weight 1,400kgf (13.7kN)5.700kgf (51.7kN)
- 3.6 Standard leader length 11.9m**
- 3.7 Maximum operating weight 43,000kgf
(421 kN)**
- 3.8 Ground contacting area with 600mm wide shoe..... 41,700cm²**
- 3.9 Ground pressure (at maximum operating weight of 43,000kgf)....1.03kgf/cm²**

Due to company policy of continuous development and improvement, the right is reserved to change the specifications without notice.

3.10 Diesel engine

- 1) **Maker** **HINO MOTOR LTD.**
- 2) **Model** **EH700 diesel engine**
- 3) **Type****Water cooled, 4-cycle, Overhead valve, in-line
6-cylinder, direct fuel injection, turbo-charged.**
- 4) **No. of cylinder x bore x stroke****6 x 110mm x 113mm**
- 5) **Total displacement** **6,443 cc**
- 6) **Compression ratio****17.9 : 1**
- 7) **Rated output** **117PS/2200rpm
(86.0 kW/2000rpm)**
- 8) **Maximum torque** **40kgf-m/1400rpm)
(392N-m/1400rpm)**
- 9) **Fuel consumption rate** **165 g/ps · hr
224g/kW · hr**
- 10) **Battery** **24V-120AH x 2 pc.**

3.11 Fuel tank capacity **250 liters**

Due to company policy of continuous development and improvement, the right is reserved to change the specifications without notice.

4. POWER TRAIN DIAGRAM (DHJ-40 BASIC MACHINE)

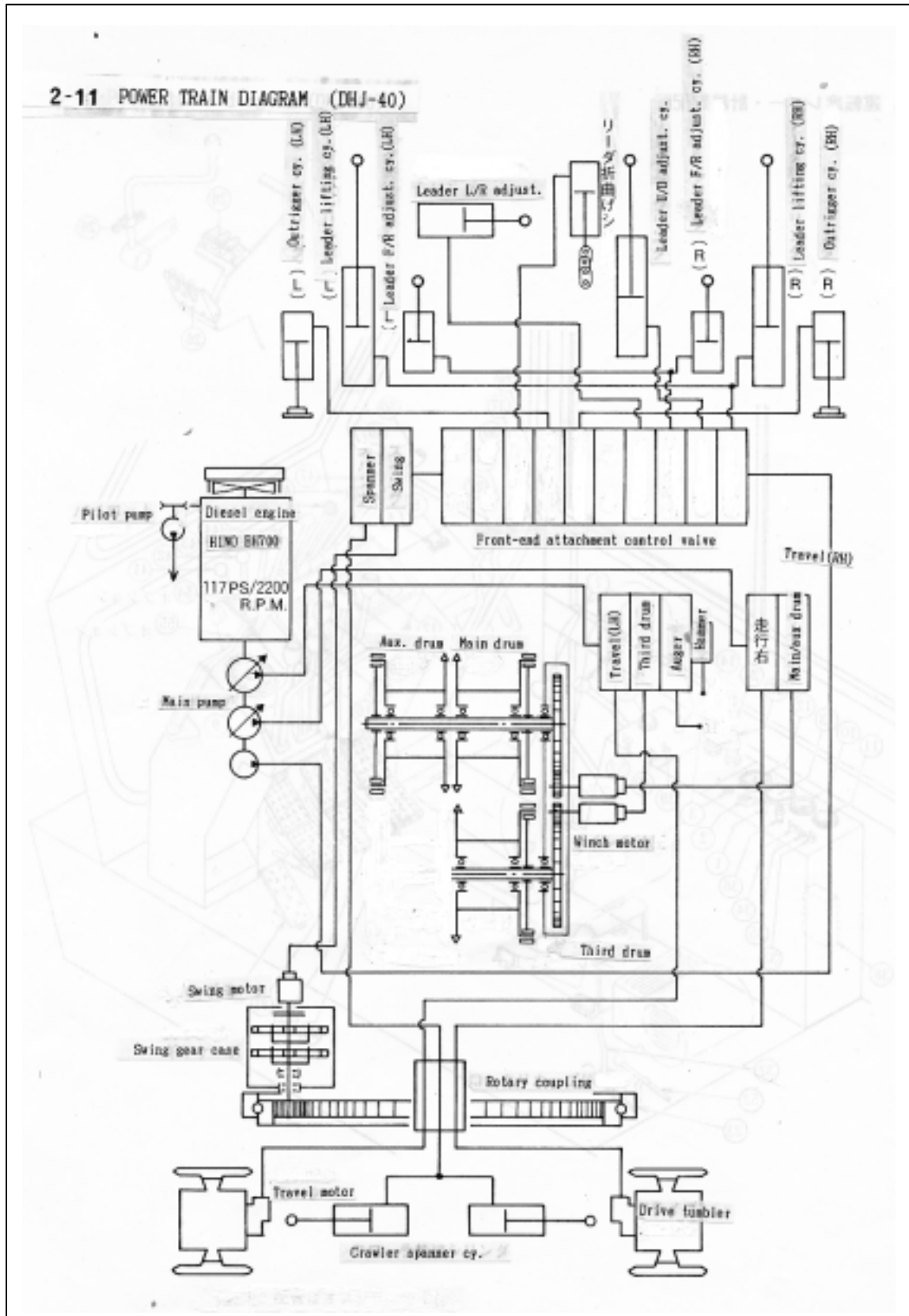

Due to company policy of continuous development and improvement, the right is reserved to change the specifications without notice.

5. STRUCTURE AND FUNCTIONS

5.1 Upper revolving superstructure

All welded, stress relieved and precision machined unit, specially designed for rigidity and durability.

5.2 Winch drums

- 1) Main, auxiliary and third winch drums are of special alloy cast iron.**
- 2) Main and auxiliary drums are mounted opposite each other on anti-friction bearings on single drum shaft and driven by one hydraulic motor. Third drum is mounted on anti-friction bearings on single drum shaft and driven through a gear box by the same hydraulic motor.**
- 3) Drum clutch system**
Main, auxiliary and third drums are equipped with internal expanding friction clutch bands powered by respective hydraulic clutch cylinders and ensure both of power controlled lowering and free-fall lowering functions.
- 4) Drum brake system**
Main, auxiliary and third drums are equipped with external contracting friction bands powered by treading respective brake pedals.
- 5) Drum pawl lock**
Main, auxiliary and third drums are equipped with pawl locks for safe operation.

5.3 Swing mechanism

- 1) Swing motor**
Axial piston motor with built-in planetary reduction gear.
- 2) Swing bearing**
Sealed ball race bearing with heat treated internal gear.
- 3) Swing brake**
Spring loaded and hydraulic released negative brake is installed.
- 4) Swing lock**
Manually operated mechanical lock with a rod tip which is engaged in the hole of track frame during transportation and assembling, whenever needed.

Due to company policy of continuous development and improvement, the right is reserved to change the specifications without notice.

5.4 Operator room

- 1) Roomy, completely independent operator's room has safety glass windshields giving super blighting and excellent all-round visibility.**
- 2) Control levers and instruments are arranged in convenient trouping, reducing unnecessary moves for operator.**
- 3) Comfortable reclining seat is adjustable.**

5.5 Undercarriage

- 1) Track frame**
All welded, stress relieved, precision machined unit, especially designed for rigidity and durability.
- 2) Side frame**
Side frame of all-welded construction can be expanded for better stability of the machine during working and retracted for transportation by hydraulic cylinders equipped as standard.
- 3) Track shoes**
Shoes are cast, heat-treated steel, flat and tapered surfaces and are connected by heat-treated steel pins.
- 4) Rollers**
Life-lubricated lower rollers, upper rollers and drive tumblers.
6 lower rollers in each side frame, with double rolling surfaces.

5.6 Hydraulic system

A semi-closed circuit hydraulic system with double-plunger pump plus 2-gear pump assures both independent and simultaneous operations of all functions.

5.6.1 Main pump (Double-plunger pump)

Due to company policy of continuous development and improvement, the right is reserved to change the specifications without notice.

1) Type	Plunger pump 1 Variable displacement Total power control	Plunger pump 2 Variable displacement Total power control
2) Setting pressure	245 kgf/cm² (240bar)	245 kgf/cm² (240bar)
3) Oil flow	223 lit./min.	223lit./min.
4) Applications	Travel (L.H.) Third drum Hammer/auger	Travel (R.H.) Main/Aux. drum

5.6.2 Gear pump

1) Type	Gear pump 1	Gear pump 2
2) Setting pressure	210kgf/cm² (205.8bar)	
3) Oil flow	177 lit./min.	
4) Applications	Swing Spanner Front-end operating attachments	Pilot circuit

5.6.3 Hydraulic motor

1) Swing motor	1-fixed volume axial piston motor with brake.
2) Winch(Main/aux.)	1-fixed volume axial piston motor with counter balance valve
3) Winch (Third) Hammer/auger	1-fixed volume axial piston motor with counter balance valve
4) Travel	2-fixed volume axial piston motor with spring loaded/ hydraulic released negative brakes and relief valves.

5.6.4 Hydraulic oil tank capacity : 280 liters

6. GENERAL VIEW OF DHJ-40, M20DS 15.5M LEADER

Due to company policy of continuous development and improvement, the right is reserved to change the specifications without notice.

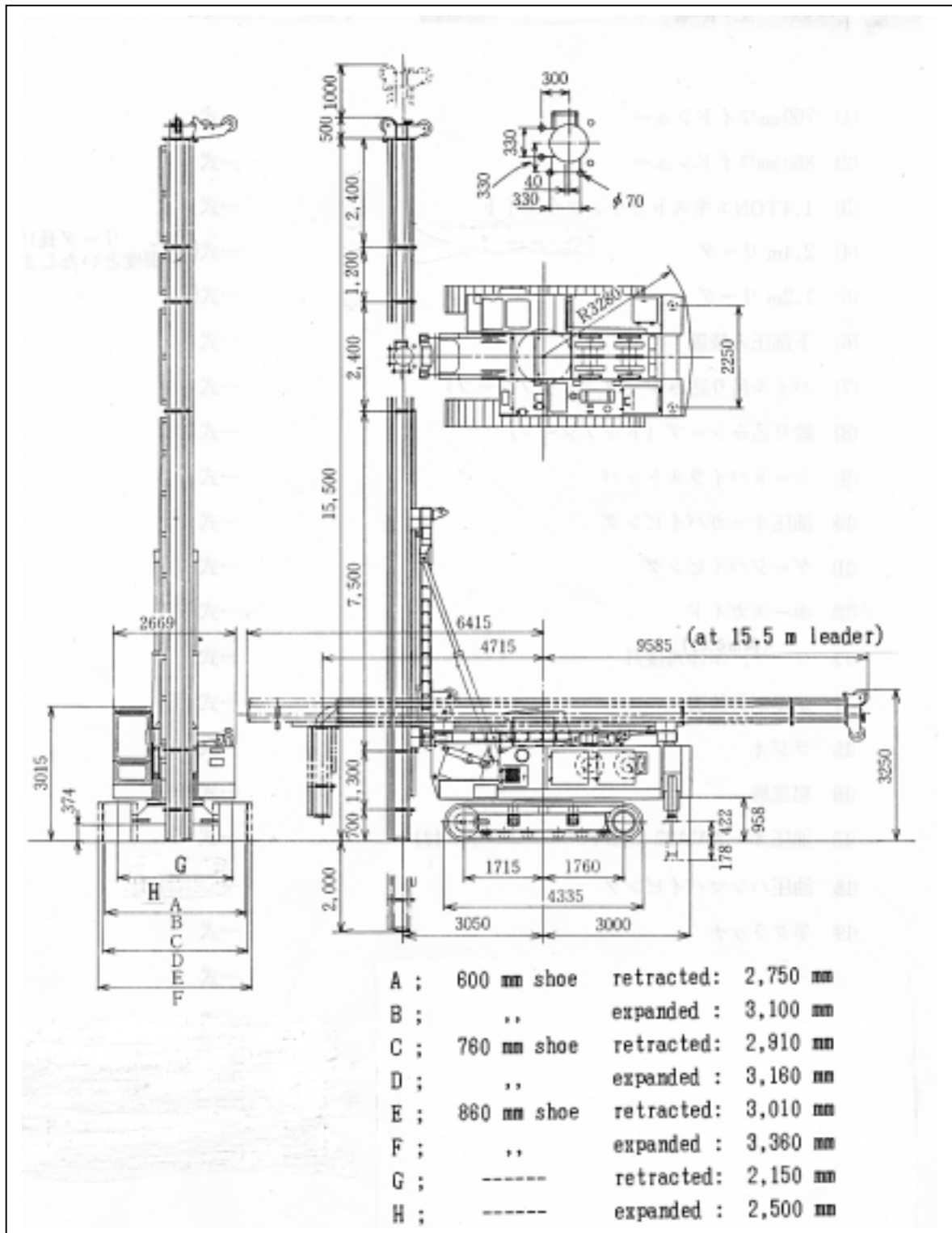

7. LEADER COMPOSITION (M20DS)

Due to company policy of continuous development and improvement, the right is reserved to change the specifications without notice.

Leader length with top sheave	18.4m	16.0m	14.8m	13.6m	12.4m	11.2m	10m	9.3m	8.0m
Leader length without top sheave	17.9m	15.5m	14.3m	13.1m	11.9m	10.7m	9.5m	8.8m	7.5m
Leader composition									
Capable pile length driven with #25 diesel hammer or NH20 hydraulic pile hammer	13m	10m	9m	8m	7m	5.5m	4.5m	3.5m	2.5m

8. Rope reeving chart and rope specification

Due to company policy of continuous development and improvement, the right is reserved to change the specifications without notice.

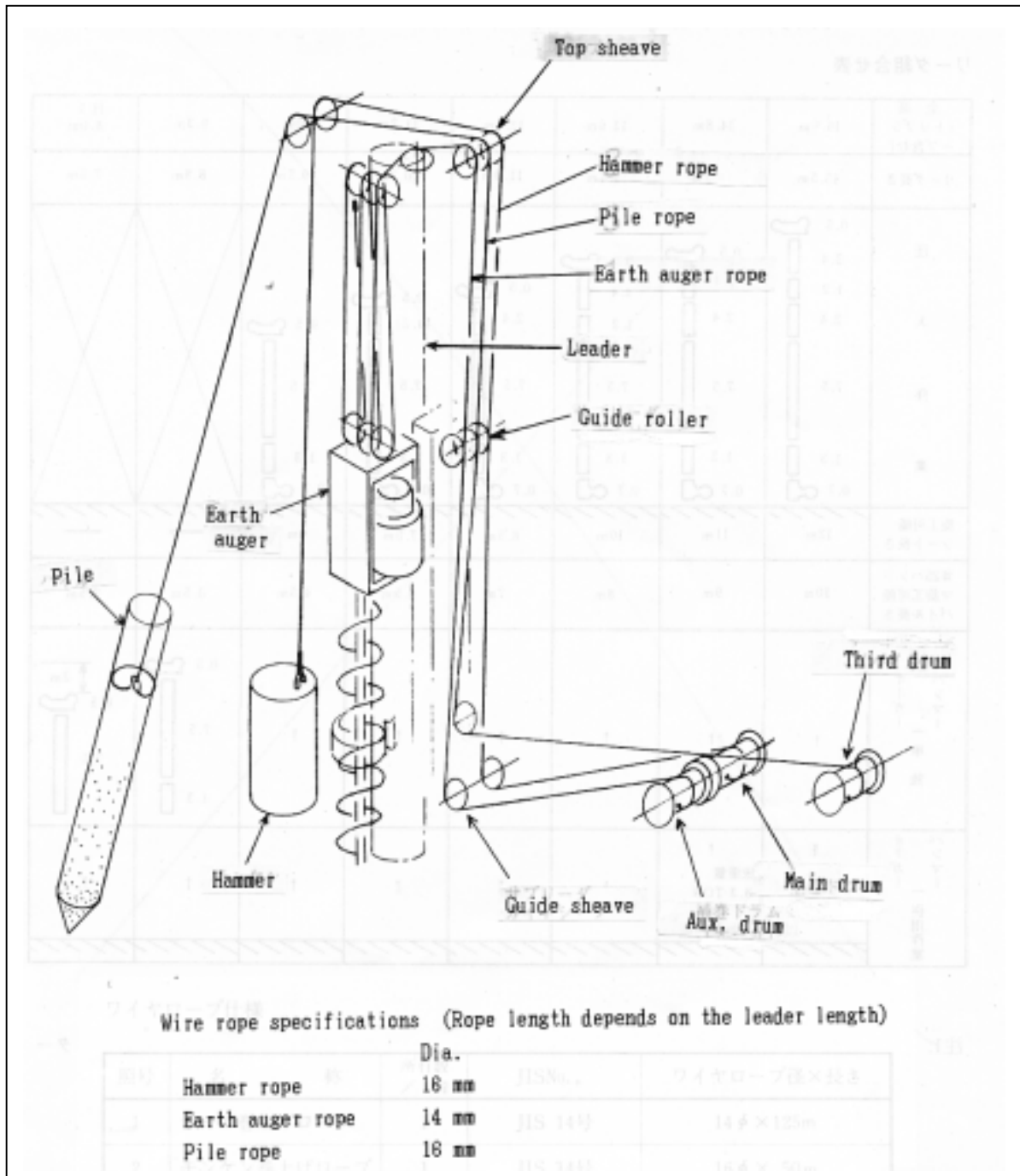

9. STANDARD SCOPE OF SUPPLY

Due to company policy of continuous development and improvement, the right is reserved to change the specifications without notice.

- 1) **Basic machine : model DHJ-40, M20DS 1 unit**
equipped with
- **4.3ton + 1.4ton counter weights**
 - **Three drums of main, auxiliary and third**
 - **Leader bracket/sub leader**
- 2) **Pile driving front-end attachments 1 set**
- Leader, Model: M20DS 15.5m long**
Single guide pipe (ϕ 70 x pitch 330)
Composed of
- **0.7m Lower leader 1pc.**
 - **1.3m middle leader 1pc.**
 - **7.5m middle leader 1pc.**
 - **2.4m upper leader 1pc.**
 - **1.2m insert leader 1pc.**
 - **2.4m insert leader 1pc.**
 - **Top sheave 1pc.**
- 3) **Standard tool set 1 set**
(As per attached)