

SPEC. F5-2823

Date: October, 1998

SPECIFICATION

“NISSHA”

Crawler Mounted Hydraulic Pile Driving Rig

**Model : DHJ60-2, M40D(A)
(Standard version)**

Quantity: unit

October, 1998

NIPPON SHARYO, LTD.

Nagoya, Japan

Tel: 81 - (52) -623-3659

Fax: 81 - (52) -623-4349

Due to company policy of continuous development and improvement, the right is reserved to change the specifications without notice.

CONTENTS

	Page
1. GENERAL CONDITIONS.....	2
2. FEATURES.....	4
3. SPECIFICATIONS OF PILE DRIVING RIG	6
4. POWER TRAIN DIAGRAM	8
5. STRUCTURE AND FUNCTIONS.....	9
6. WORKING CAPACITY TABLE.....	12
7. GENERAL VIEW OF DHJ60-2, M40D(A).....	13
8. LEADER COMPOSITION.....	14
9. ROPE REEVING CHART.....	15
10. General view of VA-35 Hydraulic auger drive	16
11. STANDARD SCOPE OF SUPPLY.....	17
12. OPTIONAL EXTRA DEVICES	17

Due to company policy of continuous development and improvement, the right is reserved to change the specifications without notice.

1. GENERAL CONDITIONS

This specification shall cover the standard specification of NISSHA, Hydraulic Pile Driving Rig; model DHJ60-2 (here-in-after called "The machine") manufactured by NIPPON SHARYO, LTD.

The general arrangement and principal dimensions of the machine are shown in the drawings attached.

1) DESIGN AND WORKMANSHIP

The machine shall be designed to perform the maximum efficiency with the least fuel consumption and the lowest maintenance costs.

The workmanship shall be of the first class in all respects.

The machine shall be built for simple mechanical arrangement and easy in inspection and maintenance.

2) MATERIALS

The materials used in the manufacture of the machine shall be of the highest quality, free from defects and imperfections.

Principal materials such as bolts, nuts, seals and steel plates used in the machine confirm to the Japanese Industrial Standards. (Almost equal to ISO)

3) TEST AND INSPECTION

Routine test and inspection in our factory shall be final.

4) PAINTING AND LETTERING

Under-coating by anti-rust paint and enamel finishing shall be performed in accordance with manufacturer's standard practice.

Main parts of the equipment shall be painted in NISSHA Green and other equipment in manufacturer's standard.

5) LANGUAGE AND UNIT OF MEASUREMENT

All documentation, such as specifications, manuals, etc. shall be written in English and all of equipment shall be designed in metric system.

6) SERVICE CONDITIONS

The equipment shall meet the following service conditions.

Ambient temperature: -10 or higher and 40 or lower.

Due to company policy of continuous development and improvement, the right is reserved to change the specifications without notice.

7) WARRANTY

All the machines specified herein shall be warranted by us for a period of twelve (12) calendar months after the date of being to put into operation, or fourteen (14) months after the date of shipment at a Japanese port, or one thousand engine operation hours according to the service hour meter, whichever is soonest.

The warranty shall cover defects in design, materials and workmanship only, shall not applicable to damage sustained mishandling of the machine or normal wear and tear.

The warranty shall not be applicable to the parts and materials mentioned below.

- 1) Linings as brake/clutch bands and disc.**
- 2) Wear plates**
- 3) Wire ropes**
- 4) Rubber made parts**
- 5) Seals as o-rings, seal rings, back-up rings, etc.**
- 6) Gaskets and sheet packings**
- 7) Filter elements**
- 8) Batteries**
- 9) Electric wiring**
- 10) Glasses**
- 11) Other quick moving parts**
- 12) Lubricants**

... concluded

Due to company policy of continuous development and improvement, the right is reserved to change the specifications without notice.

2. FEATURES

1) Rack & pinion elevation system

The hydraulic drive earth auger; model VA-35(option) which has no suspension rope but is able to go up and down smoothly by a pair of hydraulically driven pinion gears and racks provided along the leader.

This epoch making elevation system allows DHJ-60-2 safe, powerful and facile auger operation compared to the conventional cable suspension type auger drives.

2) High performance with NH-40 hydraulic pile hammer (option) and VA-35 (option) earth auger drive equipped through hydraulic power take-off from the base machine.

The machine is specially designed for various heavy duty pile driving works equipped with a hydraulic pile hammer and an earth auger drive + flight auger, or etc.

3) Durable and stable pile driving work

A durable cylindrical leader with a pair of back stay mechanism provided to specially designed basic machine for pile foundation work purposes gives a high degree of durability and stability of the machine.

4) Excellent maneuverability

The maximum allowable operating weight of 66,000kgf assures facile maneuverability in the site.

R.H. and L.H. independent traveling mechanism with a high traction force enables the machine to make both pivot and spin turns, and to steer the crawlers smoothly and continuously.

5) Smooth swing

The swing mechanism with NIPPON SHARYO original reaction device makes operator easy to control sensitive swing motion and accurate positioning of the superstructure.

6) Comfortable operator's room with low sound level

Well insulated operator room with five (5) wide wind-shields assures bright and quiet operation circumference with minimum fatigue.

7) Easy winch operation

Hydraulic actuated control levers are easy to operate, and high/low winch speed change and winging-stop/automatic braking-rewinding functions can be done by one control lever with mode indicating lamps.

Due to company policy of continuous development and improvement, the right is reserved to change the specifications without notice.

8) Low speed control

The elevation and rotation speed of VA-35 auger drive (option) can be controlled at the desired speed of 1/7 to 1/1 times of its rating.

Every winch rope line speed can be maintained at the desired constant speed by “Constant speed controller” as optional extra.

9) Easy maintenance

Adopting floating ring seals in drive tumblers, take-up tumblers and lower track rollers, and sealed bearings to every sheaves require minimum daily maintenance service. A grease-bath type swing pinion gear prolongs its service interval.

10) Low fuel consumption

The machine is powered by a direct fuel injection type diesel engine with a pair of variable displacement type plunger pumps of efficient performance, accordingly economical operation can be assured.

11) Easy re-assembling of leader at site

The leader can be stored over the superstructure for transportation and be erected easily by back stay cylinders that eliminates the required reassembling time at the job site.

Due to company policy of continuous development and improvement, the right is reserved to change the specifications without notice.

3. SPECIFICATIONS OF PILE DRIVING RIG

3.1 Model of basic machine NISSHA ; DHJ-60-2

3.2 Nominal dimensions

1) Overall width in transportation.....	3,300mm
Minimum.....	3,000mm
2) Crawler overall width in working.....	3,500mm
3) Crawler overall width in transportation.....	3,300mm
Minimum.....	3,000mm
4) Crawler center to center distance in transportation.....	2,250mm
5) Crawler center to center distance in working.....	2,740mm
6) Crawler shoe width.....	760mm
7) Crawler overall length.....	4,540mm
8) Cab width.....	3,000mm
9) Gantry height (Working).....	6,051mm
10) Overall height (Transportation).....	3,315mm
11) Rear end radius (Counterweight end)	3,825mm
12) Rear end clearance.....	970mm

3.3 Operation speed

1) Main and auxiliary drums, winding/rewinding speed (Low)	* 32m/min.
2) Main and auxiliary drums, winding/rewinding speed (High).....	* 64m/min.
3) Third drum, winding/rewinding speed.....	* 50m/min.
4) Swing speed	3.5 rpm
5) Travel speed	1.3 km/hr.
6) Gradeability (Basic machine).....	40%
7) Weight of basic machine	25,800kgf (253 kN)
9) Counterweight.....	(8,5000 + 4,000 kgf) 12,500kgf (122.3 kN)
10) Standard leader length	21m
11) Maximum permissible operating weight	66,000kgf (64.7kN))

Due to company policy of continuous development and improvement, the right is reserved to change the specifications without notice.

4. POWER TRAIN DIAGRAM (DHJ60-2 BASIC MACHINE)

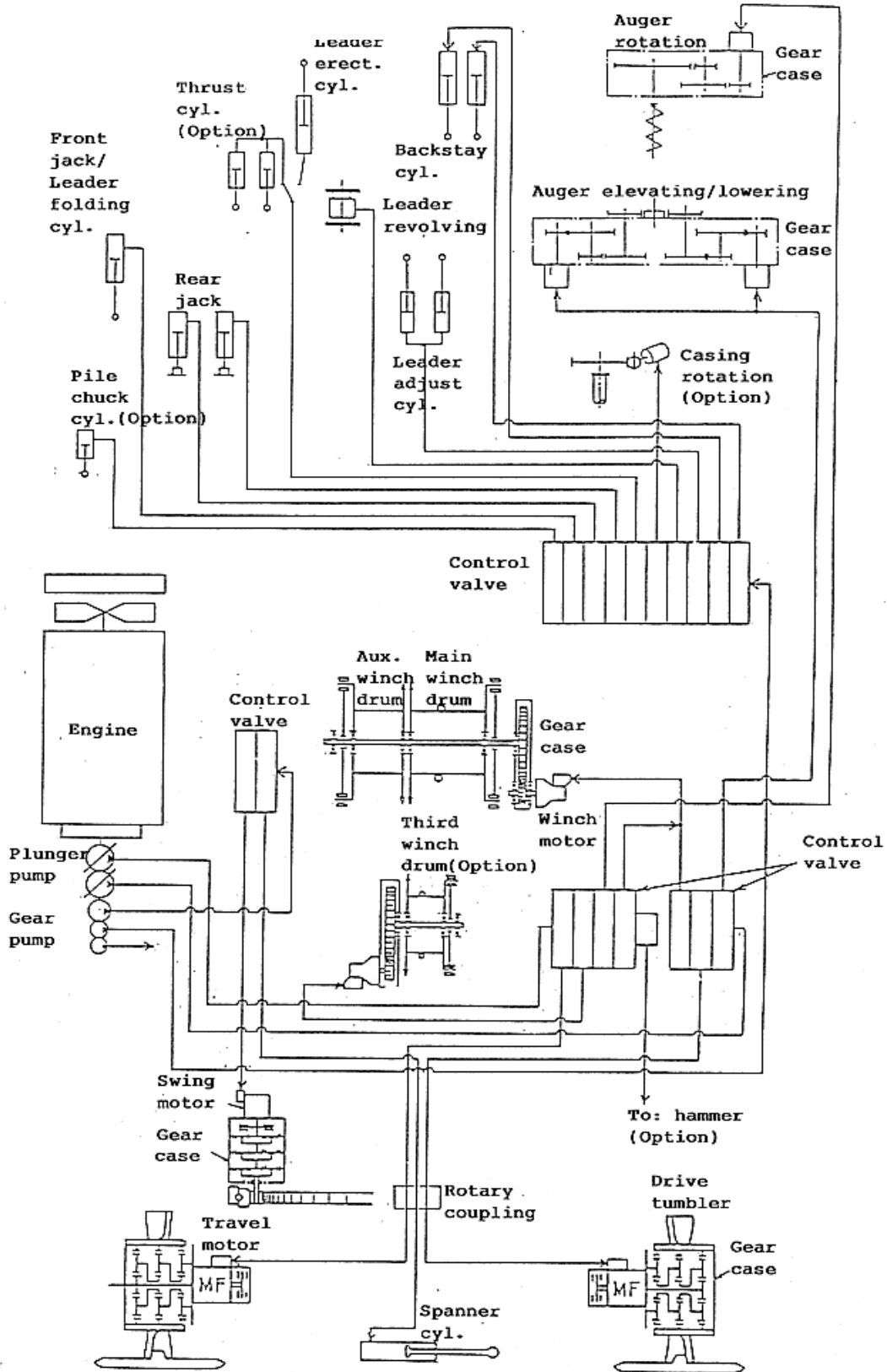

Due to company policy of continuous development and improvement, the right is reserved to change the specifications without notice.

5. STRUCTURE AND FUNCTIONS

5.1 Upper revolving superstructure

All welded, stress relieved and precision machined unit, specially designed for rigidity and durability.

5.2 Winch drums

- 1) Main, auxiliary, third and leader winch drums are of special alloy cast iron.**
- 2) Grooved leader drum is mounted on a drum shaft and driven independently by a hydraulic motor.**
- 3) Auxiliary and third drum are mounted opposite each other on ball race bearings on single drum shaft and driven by one hydraulic motor.**
- 4) Drum clutch system**
Main, auxiliary and third drums are equipped with internal expanding friction clutch bands powered by respective hydraulic clutch cylinders and ensure both of power controlled lowering and free-fall lowering actions.
- 6) Drum brake system**
Main, auxiliary and third drums are equipped with external contracting friction bands powered by treading respective brake pedals.
- 7) Leader hoisting/lowering mechanism**
Completely independent operation from other winch functions.
Both of hydraulic brake and spring-loaded/hydraulic released band brake offer positive and safe stopping of leader action.
- 8) Drum pawl lock**
Main, auxiliary, third and leader drums are equipped with electrically operated pawl locks for safe operation.

5.3 Swing mechanism

- 1) Swing motor**
Axial piston motor with built-in planetary reduction gear.
- 2) Swing bearing**
Sealed ball race bearing with a heat-treated internal gear.
- 3) Swing brake**
Spring loaded and hydraulic released negative brake is installed.
- 4) Swing lock**
Manually operated mechanical lock with a rod tip which is engaged in the hole of track frame during transportation and assembling, whenever needed.

Due to company policy of continuous development and improvement, the right is reserved to change the specifications without notice.

5.4 Operator room

Roomy, completely independent operator's room has safety glass windshields giving super blighting and excellent all-round visibility.

- 1) Control levers and instruments are arranged in convenient trouping, reducing unnecessary moves for operator.
- 2) Comfortable reclining seat is adjustable.

5.5 Undercarriage

1) Track frame

All welded, stress relieved, precision machined unit, especially designed for rigidity and durability.

2) Side frame

Side frame of all-welded construction can be expanded for better stability of the machine during working and retracted for transportation by hydraulic cylinders equipped as standard.

3) Track shoes

Shoes are casting, heat-treated steel, flat and tapered surfaces and are connected by heat-treated steel pins.

4) Rollers

Life-lubricated lower rollers, upper rollers and drive tumblers are provided.

11 lower rollers and 2 upper rollers in each side frame, with double rolling surfaces.

5.6 Hydraulic system

A semi-closed circuit hydraulic system with double-plunger pump plus 3-gear pump assures both independent and simultaneous operations of all functions.

5.6.1 Main pump (Double-plunger pump)

1) Type	Plunger pump 1 Variable displacement Total power control	Plunger pump 2 Variable displacement Total power control
2) Set pressure	280 kgf/cm ² (274 bar)	280 kgf/cm ² (274 bar)
3) Oil flow	225 lit./min.	225 lit./min.
4) Applications	Travel (L.H.) Leader drum Aux./third drum(low) Main drum(high)	Travel (R.H.) Main drum (low) Aux./third drum (high) Fourth drum(Option)

Due to company policy of continuous development and improvement, the right is reserved to change the specifications without notice.

5.6.2 Gear pump

1) Type	Gear pump 1	Gear pump 2	Gear pump 3
2) Setting pressure	210kgf/cm² (205.8bar)	175kgf/cm² (171.6 bar)	
3)Oil flow	135 lit./min.	76 lit./min.	
4)Applications	Swing Expansion of crawlers	Front-end attachments	Pilot circuit

5.6.3 Hydraulic motor

- | | |
|--------------------------|--|
| 1) Swing motor | 1-fixed volume axial piston motor with brake. |
| 2) Winch(Main) | 1-fixed volume axial piston motor with counter balance valve |
| (Aux./ third) | 1-fixed volume axial piston motor with counter valance valve |
| (Fourth) | 1-fixed volume axial piston motor with counter valance valve |
| 3) Winch (Leader) | 1-fixed volume axial piston motor with counter balance valve |
| 4) Travel | 2-fixed volume axial piston motor with spring loaded/
hydraulic released negative brakes and relief valves. |

5.6.4 Hydraulic oil tank capacity : 280 liters

Due to company policy of continuous development and improvement, the right is reserved to change the specifications without notice.

6. WORKING CAPACITY TABLE (DHJ60-2)

 **NIPPON SHARYO, LTD.**

DHJ60-2 M40D(A) working capacity

Counter-weight (t)	Hammer			Earth auger			Leader Length (m)	Pile		Vertical driving stability (with pile)	Backward inclined driving		Total operating weight (t)	Average ground pressure (kgf/cm ²)	
	Class	Weight (t)	Cap weight (t)	Class	Weight (t)	Length (m)		Screw Length (m)	Screw Weight (t)		Length (m)	Weight (t)			Angle
8.5	NH40	9.8	0.3	-	-	-	-	-	12	3.2	20°	10.8°	57.3	0.95	
	#35	8.5	0.7	-	-	-	-	-	15	3.3	20°	7.5°	57.1	0.94	
	#25	5.3	0.5	-	-	-	-	-	16	5.0	20°	8.0°	53.7	0.89	
	NH20	5.4	0.2	-	-	-	-	-	16	5.0	20°	8.2°	53.5	0.88	
	-	-	-	VA35	3.5	17	2.6	21	5.0	15	5.0	-	-	54.7	0.90
	#25	5.3	0.5	VA35	3.5	14	1.7	18	3.6	13	5.0	-	-	58.7	0.97
12.5	NH20	5.4	0.2	VA35	3.5	14	1.7	18	3.5	5.0	-	-	58.5	0.97	
	#45	11.0	1.5	-	-	-	-	-	21	4.2	20°	6.6°	64.4	1.06	
	NH40	9.8	0.3	-	-	-	-	-	21	6.9	20°	5.9°	62.0	1.02	
	#35	8.5	0.7	-	-	-	-	-	15	7.0	20°	5.9°	61.1	1.01	
	-	-	-	VA35	3.5	17	2.6	21	5.0	15	9.3°	-	-	58.7	0.97
	#25	5.3	0.5	VA35	3.5	17	2.6	21	5.0	16	5.7°	-	-	64.5	1.07
NH20	5.4	0.2	VA35	3.5	17	2.6	21	5.0	16	5.6°	-	-	64.3	1.06	

(Remarks)

1. This table shows the working capacity at the standard specifications with crawlers expanded.
2. Use rear jacks in case of leader self-erection.
3. Pile lifting rope carries 5 tons with one-part line and 10 tons with two-part line of both 20 mm in dia. The rope must be used within its permissible lifting loads.
4. Total operating weight does not include a pile weight.

Due to company policy of continuous development and improvement, the right is reserved to change the specifications without notice.

7. GENERAL VIEW OF DHJ60-2, M40D(A)- 18M LEADER

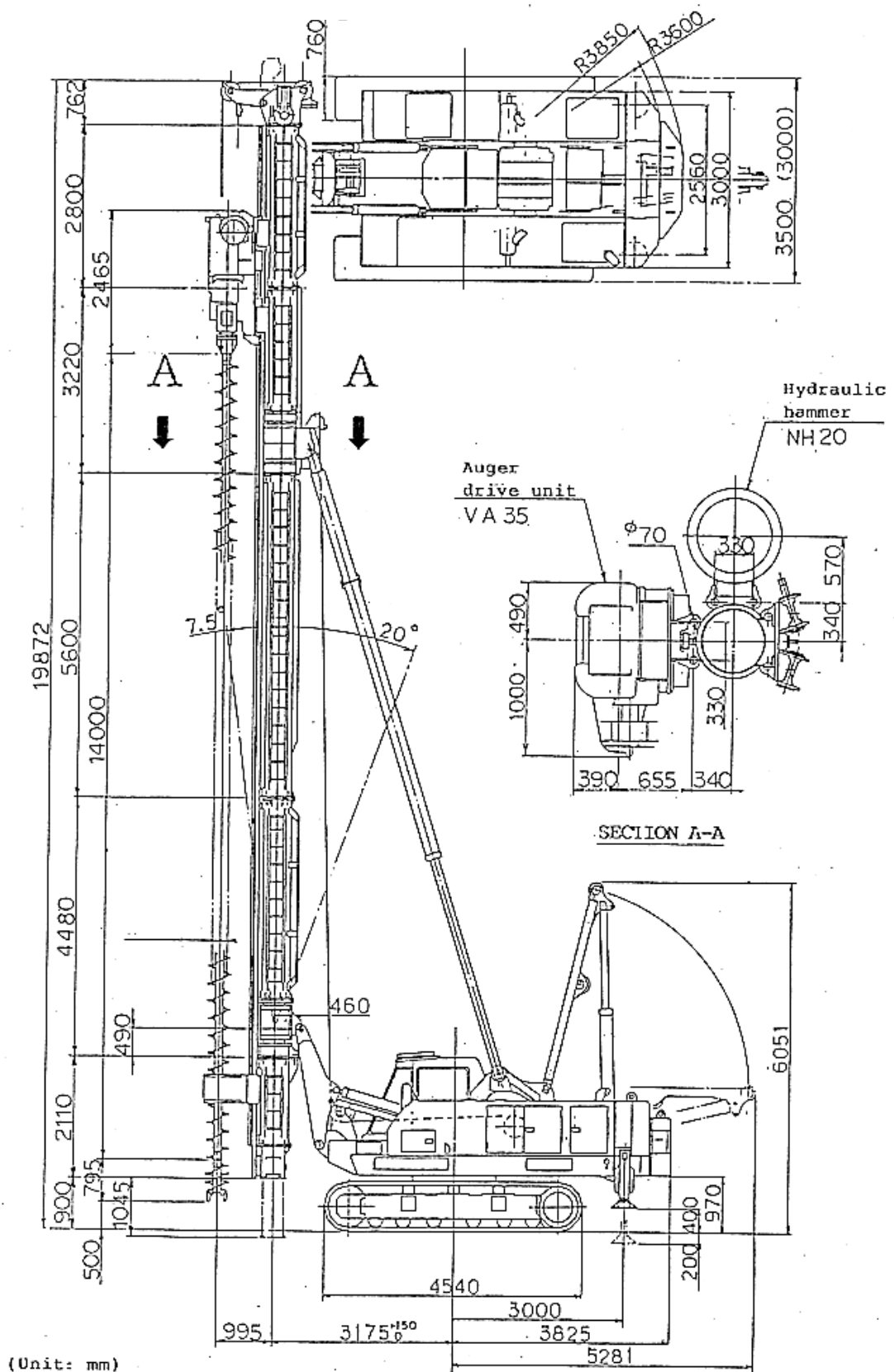

Due to company policy of continuous development and improvement, the right is reserved to change the specifications without notice.

8. LEADER COMPOSITION, Type : M40D(A)

F. Leader composition

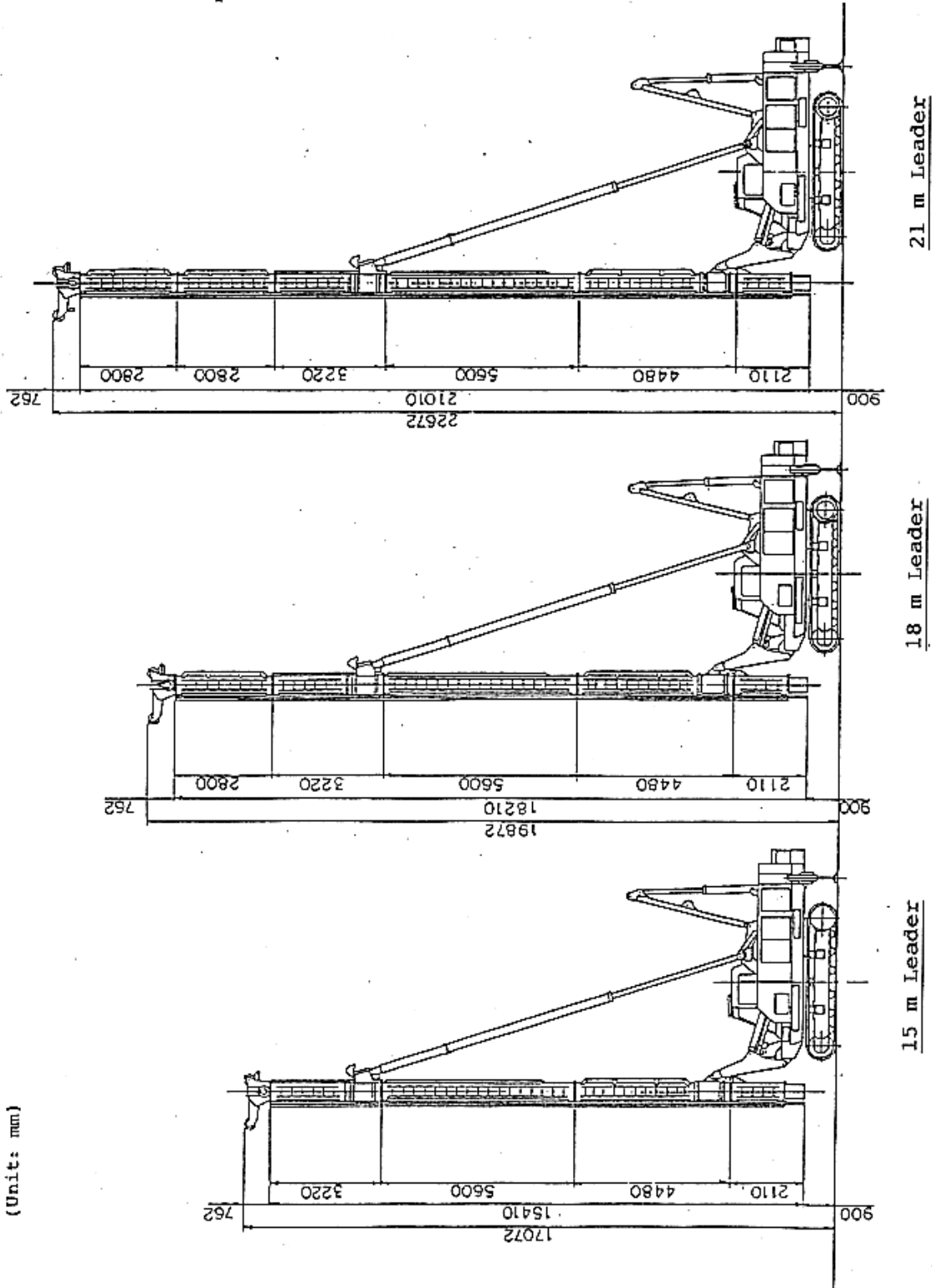

Due to company policy of continuous development and improvement, the right is reserved to change the specifications without notice.

9. Rope reeving chart

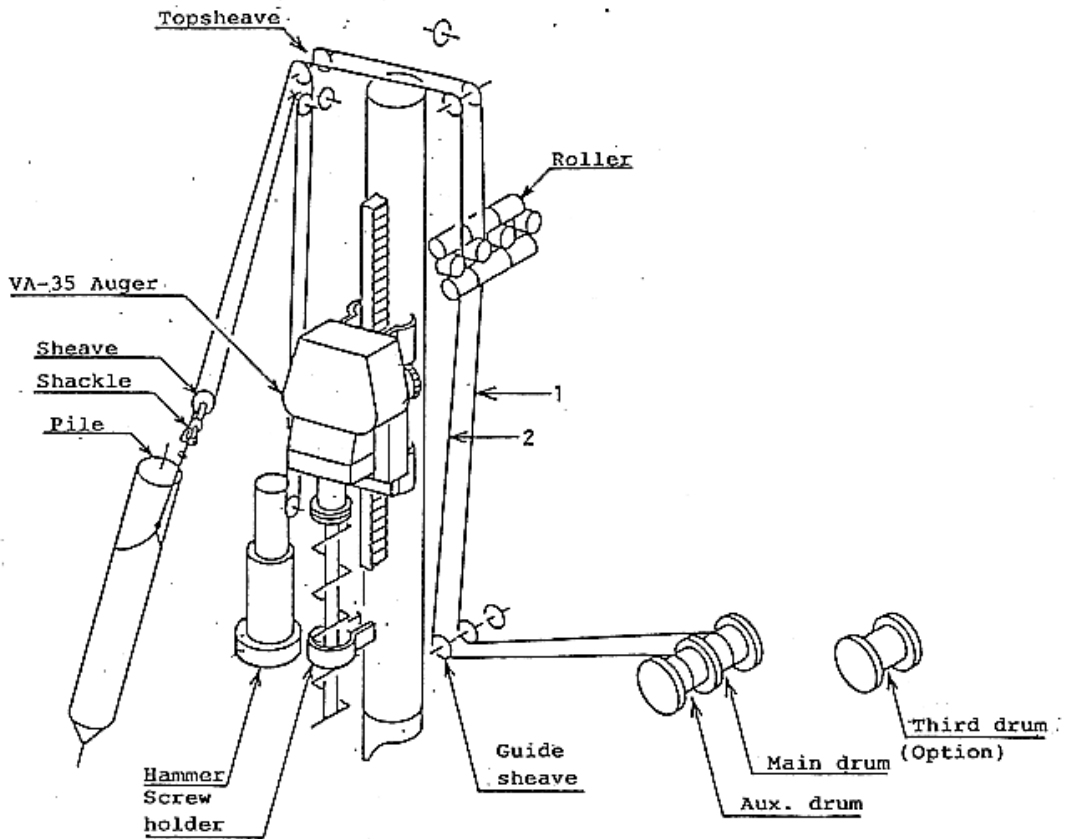

SPECIFICATIONS

No.	Name of wirerope	Rope construction	Rope dia.	Rope length
1.	Hammer hoisting-rope	6xPi(29)IWRC, Right hand (Z) ordinary lay, 30 kgf/cm ² or more of permissible breaking load	20 mm	150 m
2.	Pile lifting rope	- ditto -	20 mm	90 m

Due to company policy of continuous development and improvement, the right is reserved to change the specifications without notice.

10 General view of VA-35 hydraulic auger drive

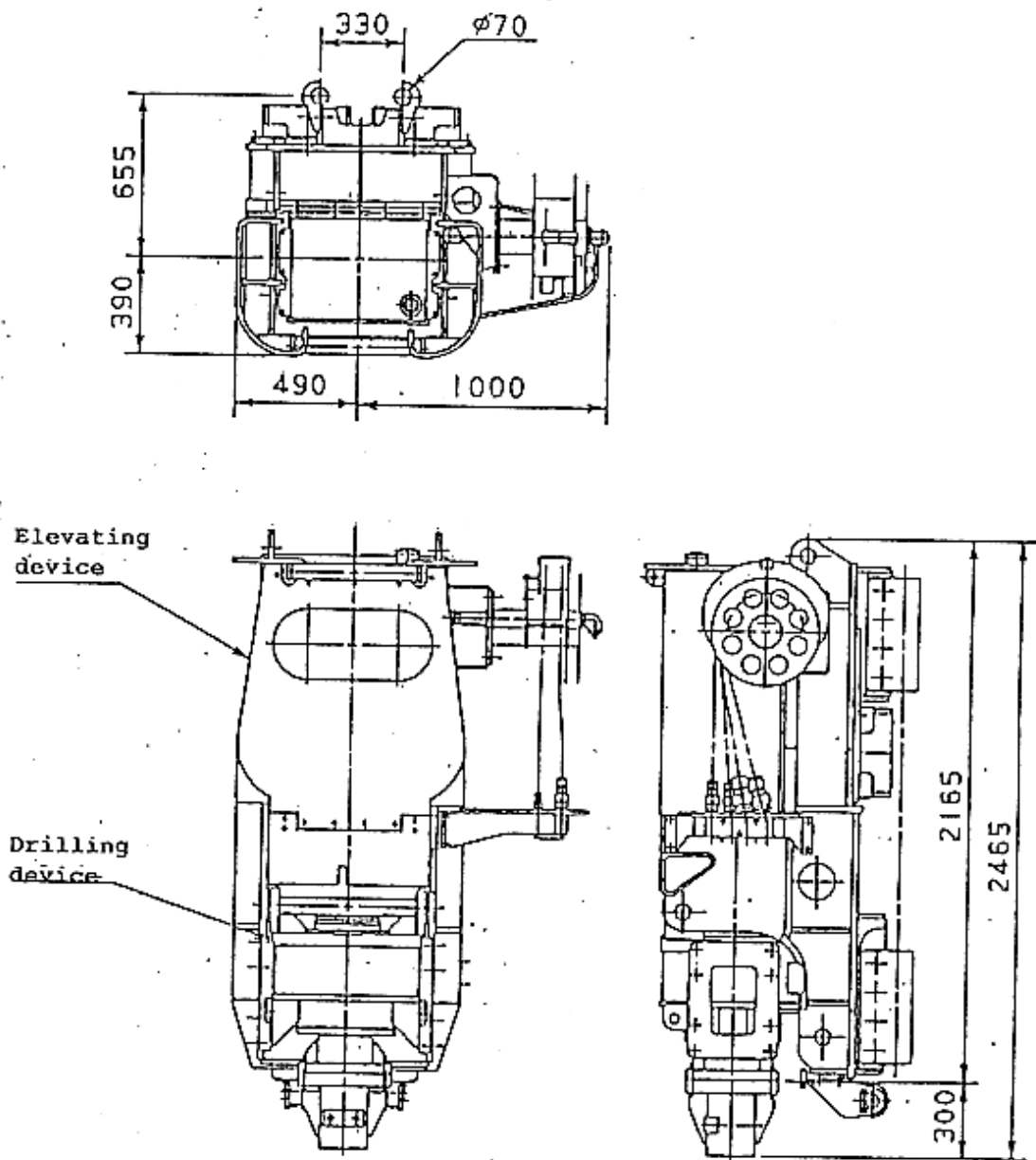

(Unit: mm)

Due to company policy of continuous development and improvement, the right is reserved to change the specifications without notice.

11 STANDARD SCOPE OF SUPPLY

- 1) **Basic machine : model DHJ60-2** **1 unit**
equipped with
- **12.5 ton counter weight**
 - **Four drums of main, auxiliary, third and leader**
 - **Leader bracket**
 - **A pair of self-erecting jack**
 - **A pair of outrigger jacks**
 - **Electric fan in operator's in operator's cab**
 - **Radio**
 - **Electric fuel pump**
 - **Ash tray and sight level gauge with a bubble**
- 2) **Pile driving front-end attachments** **1 set**
- **Leader, Revolving type Model: M40D(A)** **21m long**
 - **Double guide pipe (70 x pitch 330)**
 Composed of

2.11m lower leader	1pc.
10.08m revolver	1pc.
3.22m Lower leader	1pc.
2.8 m upper leader	1pc.
2.8 m upper leader	1pc.
Top sheaves assembly	1set
- 3) **Standard tool set** **1 set**

12 OPTIONAL EXTRA DEVICE

- **Inclinometer** **1 set**
 (Basic machine and leader)
- **Hydraulic P.T.O for hydraulic pile hammer**..... **1 set**
- **Air conditioner in operator's cab** **1 set**
- **VA-35 earth auger drive** **1 set**
- **Screw**..... **As desired**